



1.8 - VALVOLA DI BLOCCO PILOTATA A DOPPIO EFFETTO CILINDRICA

1.8 - CYLINDRIC DOUBLE PILOT OPERATED CHECK VALVE

TIPO/TYPE
VBPDE CYL

SCHEMA IDRAULICO
HYDRAULIC DIAGRAM

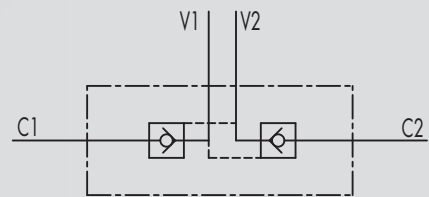
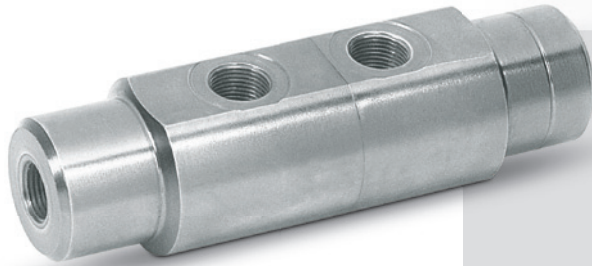

IMPIEGO:

Valvola utilizzata per bloccare in posizione un cilindro in entrambi i sensi, consentendo il flusso in una direzione ed impedendolo in senso contrario fino a quando non viene applicata la pressione di pilotaggio. E' caratterizzata dalla forma cilindrica del corpo anziché a parallelepipedo.

MATERIALI E CARATTERISTICHE:

Corpo: acciaio zincato

Componenti interni: acciaio temprato termicamente e rettificato

Guarnizioni: BUNA N standard

Tenuta: a cono guidato. Non ammette trafilamenti

MONTAGGIO:

Collegare V1 e V2 all'alimentazione e C1 e C2 all'attuatore.

USE AND OPERATION:

Pilot check valves are used to block the cylinder in both directions. Flow is free in one direction and blocked in the reverse direction until pilot pressure is applied. Cylindrical type instead of the standard one (parallelepiped).

MATERIALS AND FEATURES:

Body: zinc-plated steel

Internal parts: hardened and ground steel

Seals: BUNA N standard

Poppet type: superior valves seating by means of a machined cone; any leakage.

APPLICATIONS:

Connect V1 and V2 to the pressure flow and C1 and C2 to the actuator.

PERDITE DI CARICO PRESSURE DROPS CURVE

Temperatura olio: 50°C - Viscosità olio: 30 cSt
Oil temperature: 50°C - Oil viscosity: 30 cSt

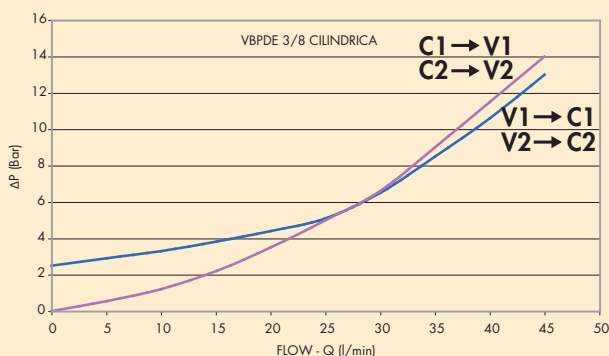



CODICE
CODE

SIGLA
TYPE

RAPP.PILOT.
PILOT RATIO

PORTATA MAX
MAX FLOW
Lt./min

PRESSIONE MAX
MAX PRESSURE
Bar

PRESSIONE APERTURA
CRACKING PRESSURE
Bar

V0055

VBPDE 3/8" CILINDRICA

1 : 5

45

350

3

1

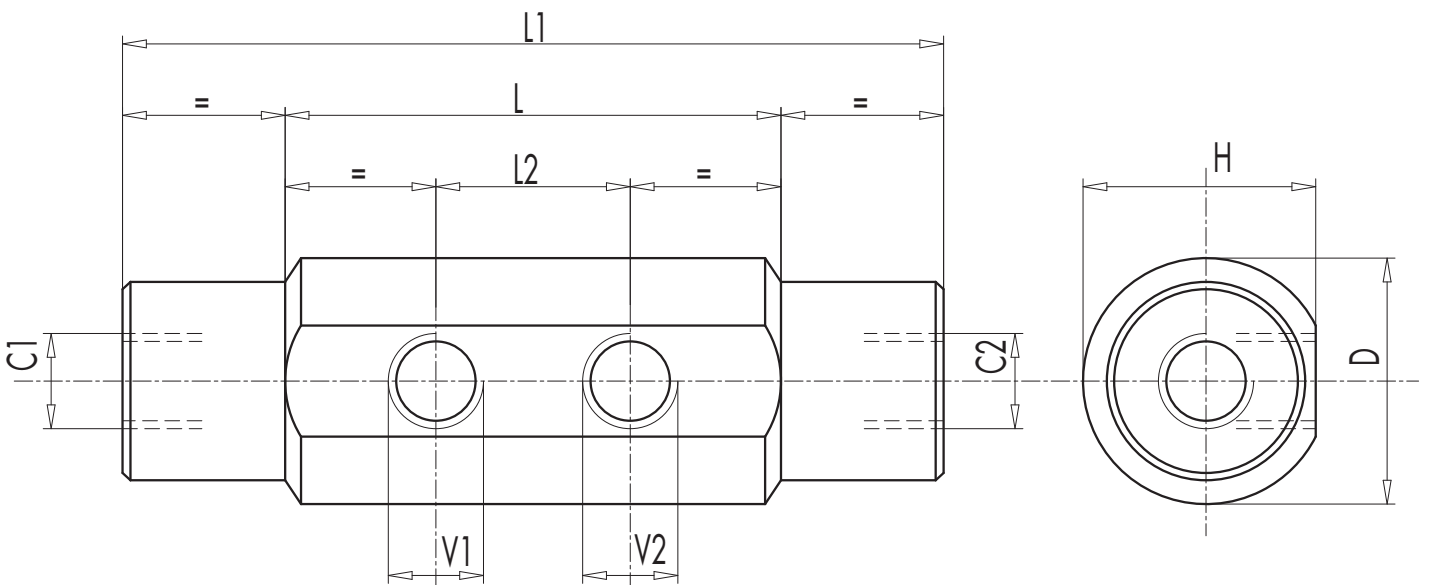

CODICE
CODE

SIGLA
TYPE

V1-V2
C1-C2

L

L1

L2

H

D

PESO
WEIGHT

V0055

VBPDE 3/8" CILINDRICA

G 3/8"

100

156

41

44

Ø 48

1,634