

D3M

SECTIONAL VALVE



 **hydro
control**
TECHNICAL CATALOGUE

1st edition D3M.05

*This catalogue shows the product in the most standard configurations.
Please contact our Sales Dpt. for more detailed information or special requests.*

WARNING!

*All specifications of this catalogue refer to the standard product at this date.
Walvoil, oriented to a continuous improvement, reserves the right to
discontinue, modify or revise the specifications, without notice.*

**WALVOIL IS NOT RESPONSIBLE FOR ANY DAMAGE CAUSED BY AN
INCORRECT USE OF THE PRODUCT.**



Applications

Numerous integrated valve features in addition to countless configuration options make D3M highly flexible and easily adaptable to the widest applications range.

The valve is available with manual, direct electric, hydraulic remote, pneumatic, electrohydraulic and electropneumatic controls.

Numerous configurations and solutions are possible.

Working sections have auxiliary valves and a broad range of interchangeable spools.

D3M has available:

Direct electric control push push type and push pull type.

Special inlet section for parallel valves connection (suitable for forest applications).

Potentiometer and microswitch kits and Overcenter spool (Fork lift trucks).





QUICK REFERENCE GUIDE

GENERAL SPECIFICATION	D9	D3M	DVS10	D4	D6	D16	D12	DVS20	D20	D25	D40
Working sections number	1-12	1-12	1-12	1-12	1-12	1-12	1-12	1-12	1-12	1-12	1-10
CIRCUIT											
Parallel	•	•	•	•	•	•	•	•	•	•	•
Series	•	•	•	•	•	•	•		•	•	
Tandem	•	•	•	•	•	•		•	•		
Parallel circuit stroke (mm)	6	5	6	6	7	7	9,5	9,5	9,5	12	15
Series circuit stroke (mm)	6	5	6	6	5	7	6,5		6,5	8,5	
Float spool extra stroke (mm)	5	5	5	5,5	6	7	7	7	7	9,5	10
Spools pitch (mm)	31	38	35	40	46	46	56	56	64	75	91
RATED FLOW											
Max recommended flow rate (l/min)	35	55	45	80	100	150	180	250	250	380	700
Max recommended flow rate (GPM)	10	15	12	22	27	40	48	67	67	100	185
RATED PRESSURE											
Max working pressure (bar)	350	350	350	350	350	350	350	250	350	350	350
Max working pressure (PSI)	5000	5000	5000	5000	5000	5000	5000	4000	5000	5000	5000

OPTION CHART	D9	D3M	DVS10	D4	D6	D16	D12	DVS20	D20	D25	D40
Direct acting pressure relief valve	•	•	•	•							
Pilot operated pressure relief valve		•		•	•	•	•	•	•	•	•
2 stage pilot operated relief valve		•		•	•	•	•		•	•	•
Externally piloted valve	•	•	•	•	•	•	•		•	•	•
Solenoid dump valve (12 Vdc)	•	•	•	•	•	•	•				
Solenoid dump valve (24 Vdc)	•	•	•	•	•	•	•				
Main anticavitation check valve		•		•	•	•	•	•	•	•	•
Clamping valve		•	•	•							
SPOOL ACTUATION											
Manual control	•	•	•	•	•	•	•	•	•	•	•
Without lever	•	•	•	•	•	•	•	•	•	•	•
90° joystick control		•	•	•	•	•					
Hydraulic control	•	•	•	•	•	•	•	•	•	•	•
Direct electric control (12-24 Vdc)		•		•							
SPOOL RETURN ACTION											
Spring return	•	•	•	•	•	•	•	•	•	•	•
Detent in A - in B - in A/B	•	•	•	•	•	•	•	•	•	•	•
Detent in 4 th position	•	•	•	•	•	•	•	•	•	•	•
Arrangement for dual control	•	•		•	•	•	•		•		
Hydraulic load limit	•	•		•	•	•					
Pneumatic control ON - OFF		•	•	•	•	•	•	•	•		
Proportional pneumatic control		•	•	•	•	•	•	•	•		
Electrical load limit	•	•		•	•	•					
Electrohydraulic control ON-OFF (12-24 Vdc)		•	•	•	•	•	•	•	•		
Electrohydraulic control PROP. (12-24 Vdc)		•	•	•	•	•	•	•	•		
Electropneumatic control (12-24 Vdc)		•	•	•	•	•	•		•		
AUXILIARY VALVES											
Antishock valve	•	•	•	•	•	•	•	•	•	•	•
Anticavitation valve	•	•	•	•	•	•	•	•	•	•	•
Combined valve	•	•	•		•	•	•		•	•	•
Pilot combined valve						•		•	•	•	•



GENERAL INDEX

4	<p>General specifications Standard working conditions Fluid options</p>	36	<p>Outlet section (version 1 outlet) Order example</p>
5	<p>Order example Standard thread Tie-rod kit classification Painting</p>	36	<p>Outlet section (HPCO version outlet) Order example - HPCO version outlet Outlet with single tank classification Outlet with two tanks classification Carry-over connection (HPCO)</p>
7	<p>Dimensions</p>	40	<p>D3M Spare parts list Gasket kit</p>
8	<p>Typical curves Pressure drop (P - T) Pressure drop (P - A/B) Pressure drop (A/B - T) Direct relief valve curve Pilot operated relief valve curve Antishock valve curve Combined valve curve Main anticavitation check valve curve Anticavitation check valve curve</p>	43	<p>Installation Guidelines General clamping torque</p>
10	<p>Inlet Section Order example Inlet side classification Valve identification Valve arrangement Inlet position and available thread type</p>	45	<p>General conditions and patents Product identification</p>
14	<p>Working section Order example Spool identification Spool actuation classification for manual control Spool actuation classification for hydraulic control Direct electrical control classification Joystick control classification Spool return action classification Direct electrical control identification Pneumatic control classification Electropneumatic control classification Load limit classification Electrical load limit classification Electrohydraulic control classification Compatibility table Work section identification Auxiliary valves identification</p>		
30	<p>Intermediate inlet section Order example Intermediate inlet section classification Valve identification on intermediate inlet section Valve arrangement on intermediate inlet section Inlet position and available thread type</p>		
33	<p>Intermediate outlet section Order example Intermediate outlet section classification Inlet position and available thread type (for BF intermediate) Inlet position and available thread type (for BG intermediate)</p>		



GENERAL SPECIFICATIONS

Standard working conditions

Description	Value
Ambient operating temperature range	-40°C / +60°C
Kinematic viscosity range	10 ÷ 300 cSt
Max contamination level	9 (NAS 1638) - 20/18/15 (ISO 4406:1999)
Recommended filtration level	$\beta_{10} > 75$ (ISO 16889:2008)
Internal filter (on electroproportional valves pilot line)	30 μm

All information and diagrams in this catalogue refer to a mineral base oil VG46 at 50°C temperature (32 cSt kinematic viscosity)

Fluid options

Types of fluid (according to ISO 6743/4) Oil and Solutions	Temperature (°C)		Compatible gasket
	min	max	
Mineral Oil HL, HM (or HLP acc. to DIN 51524)	-25	+80	NBR
Oil in water emulsions HFA	+5	+55	NBR
Water in oil emulsions HFB	+5	+55	NBR
Polyglycol-based aqueous solution HFC	-10	+60	NBR

For special applications and different fluids, please call our Technical Department.



ORDER EXAMPLE

D3M/1: IR 001 150 A G04 W001A H001 F001A RP G04 01 PA 100 05 PB TJ A G04

TYPE:
D3M: product type
/1: working section number

- 1) INLET ARRANGEMENT: (page 10)**
IR 001 inlet side and valve type
150 setting (bar)
A G04 inlet position and available thread type

- 2) WORK SECTION ARRANGEMENT: (page 14)**
W001A spool type
H001 spool actuation type
F001A spool return action type
RP G04 type and thread section
01 PA 100 auxiliary valve (port A)
05 PB auxiliary valve (port B)

- 3) OUTLET ARRANGEMENT: (page 36)**
TJ outlet type
A G04 outlet position and available thread type

Ordering row 2 must be repeated for every work section

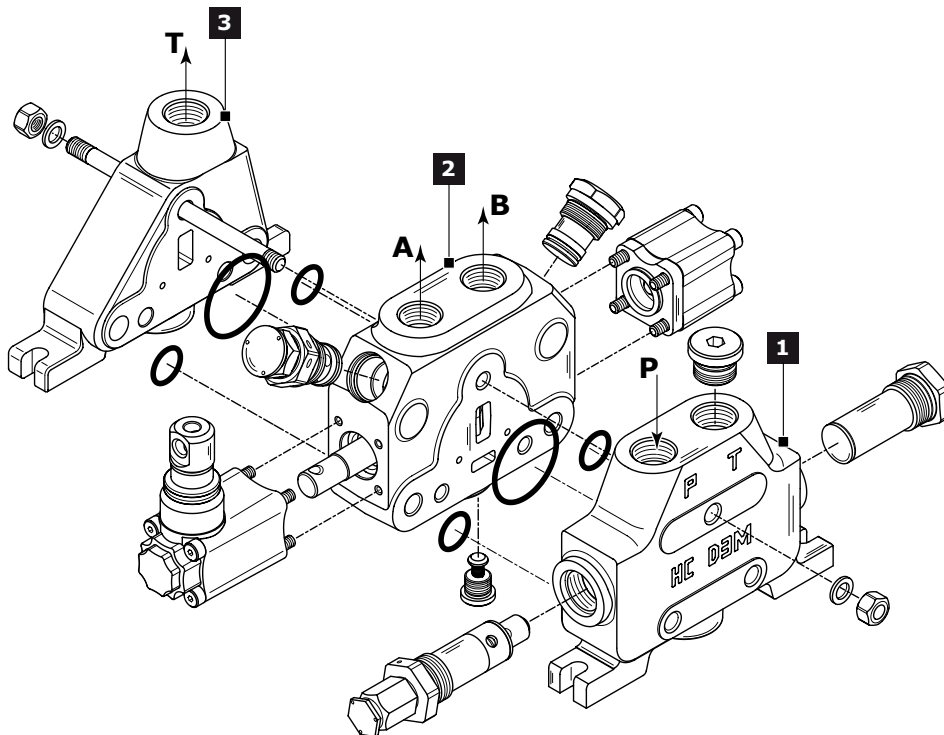

Standard thread

The connection ports size is indicated by an ordering code common for all Hydrocontrol products. Following table shows all available connections; for ordering code refer to table on page 44.

Ports	BSP (ISO - 228)	Code	UN-UNF (ISO - 725)	Code	METRIC (ISO-262)	Code
Inlet Port (P)	G 1/2	G04	3/4" - 16 UNF	U03	M18 x 1.5	M01
Ports (A - B)	G 1/2	G04	3/4" - 16 UNF	U03	M18 x 1.5	M01
Outlet (T) - Carry over (HPCO)	G 1/2	G04	3/4" - 16 UNF	U03	M55 x 1.5	M02
Hydraulic Pilot	G 1/4	G02	9/16" - 18 UNF			
Pneumatic Pilot	G 1/8	-	NPTF 1/8-27			



Tie-rod kit classification (appendix "A")

Tie rod kit allows the correct assembly of sectional valves. Tie rod's length depends on the number of sections; each valve is assembled with tie rod kits including a tie rod, two nuts and two washers. D3M requires 3 tie-rod kits.

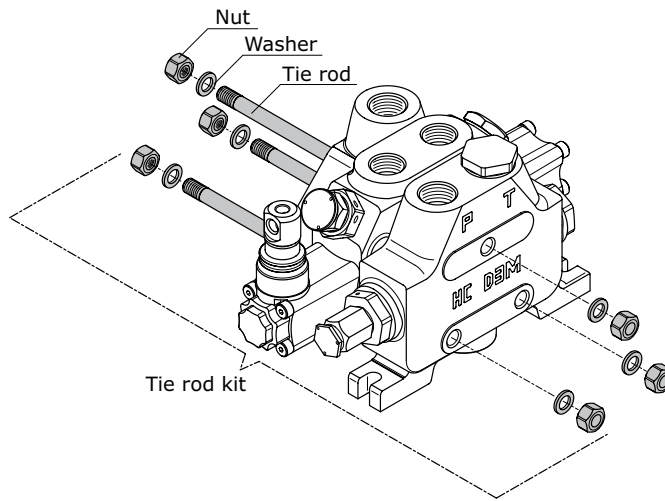

Tie rod kit	Order Code	Lenght (mm)	Clamping Torque (Nm)	Quantity
D3M/1	300130001	132		
D3M/2	300130002	170		
D3M/3	300130003	208		
D3M/4	300130004	246		
D3M/5	300130005	284		
D3M/6	300130006	322	35	3
D3M/7	300130007	360		
D3M/8	300130008	398		
D3M/9	300130009	436		
D3M/10	300130010	474		
D3M/11	300130011	512		
D3M/12	300130012	550		

Painting

On request, all Hydrocontrol valves can be delivered painted (RAL 9005 black primer).

Order example of D3M/1 painted:

D3M/1
 IR 009 150 A G04
 W001A H001 F001A RP G04 01 PA 100 01 PB 120
 TJ A G04
P006/1 N10

The painting is indicated with the following value:

P006 - /1 - N10





DIMENSIONS

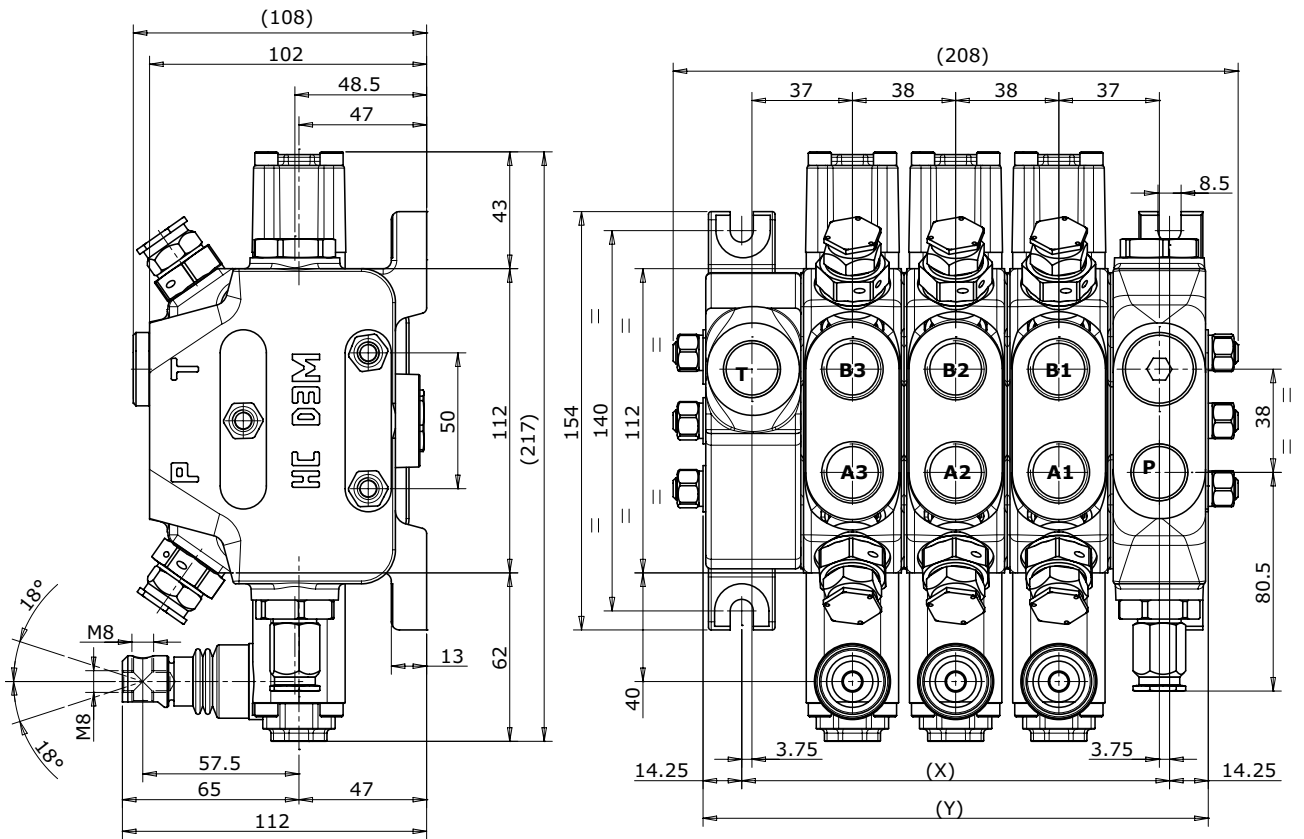

TYPE	/1	/2	/3	/4	/5	/6	/7	/8	/9	/10	/11	/12
X (mm)	81.5	119.5	157.5	195.5	233.5	271.5	309.5	347.5	385.5	423.5	461.5	499.5
Y (mm)	110	148	186	224	262	300	338	376	414	452	490	528
Weights (kg)	6.3	8,8	11.2	13.7	16.2	18.6	21	23.5	26	28.5	31	33.3



TYPICAL CURVES

Indicated values have been tested with standard sectional valve and W001A spool.

Pressure drop (P - T)

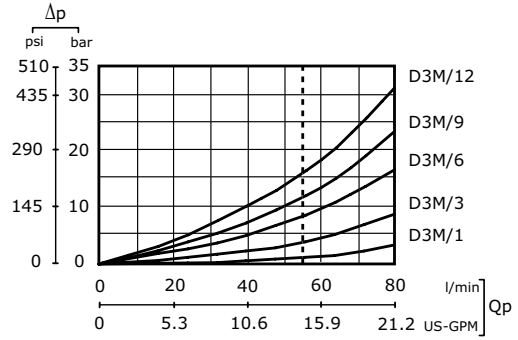
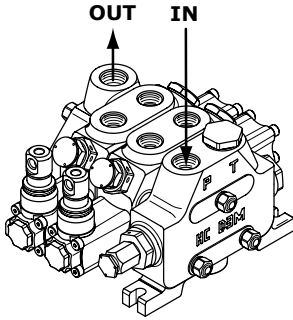

Pressure drop (P - A/B)

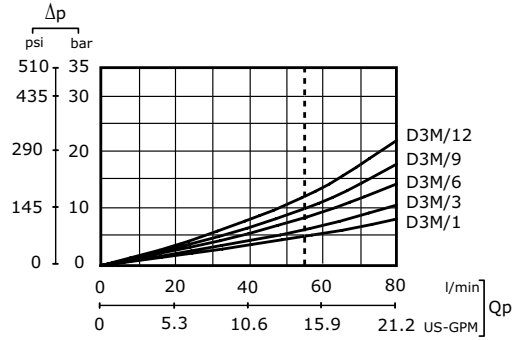
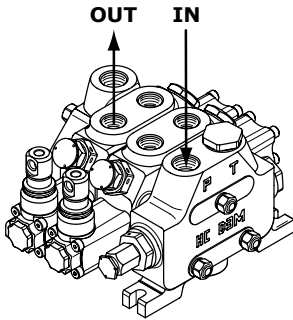

Pressure drop (A/B - T)

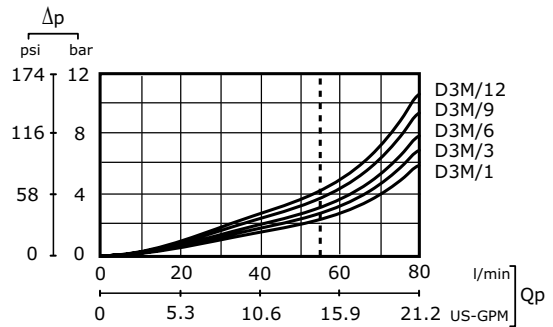
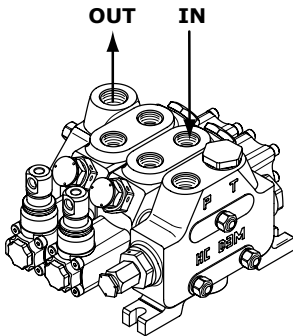

Direct relief valve curve

Setting ranges	
type	pressure (bar)
A	30 - 110
B	111 - 150
C	151 - 200
D	201 - 250
E	251 - 350

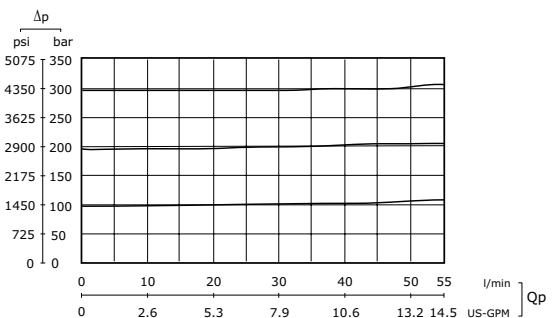



TYPICAL CURVES

Indicated values have been tested with standard sectional valve and W001A spool.

Pilot operated relief valve curve

Setting ranges	
type	pressure (bar)
A	30 - 350

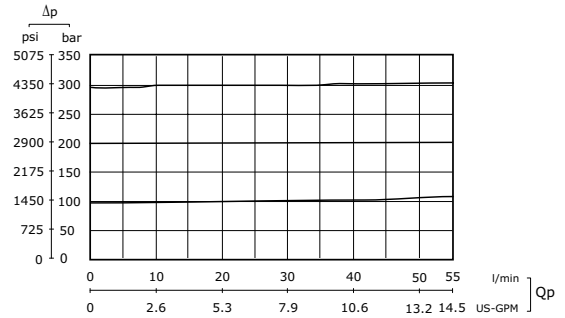

Antishock valve curve

Setting ranges		
type	pressure (bar)	
	at full flow	at min. flow
A	20 - 100	10-A / 80-A
B	101 - 220	81-A / 180-A
C	221 - 350	181-A / 350-A

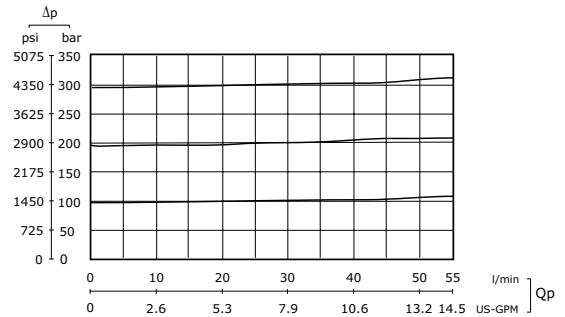

Combined valve curve

Setting ranges		
type	pressure (bar)	
	at full flow	at min. flow
A	20 - 60	10-A / 40-A
B	61 - 100	41-A / 80-A
C	101 - 220	81-A / 180-A
D	221 - 350	181-A / 350-A

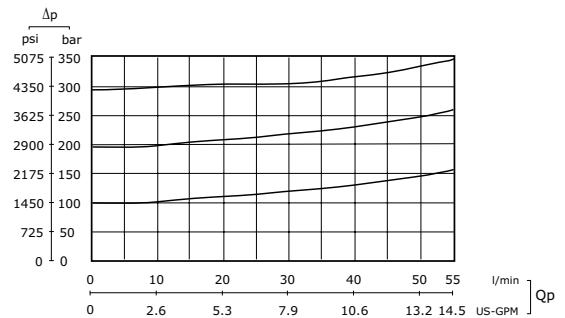

Main Anticavitation check valve curve

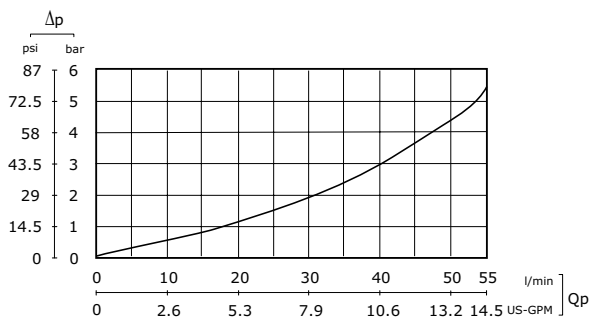

Anticavitation check valve curve

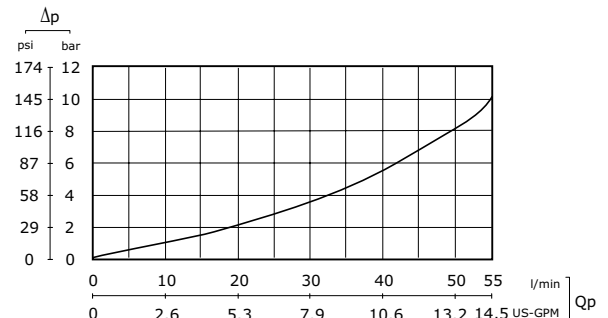



INLET SECTION

Order example

IR	001	150	A G04
----	-----	-----	-------

- IR** inlet side classification _____
- 1. 001** valve arrangement _____
- 150** setting (bar) _____
- 2. A G04** inlet position and available thread type _____

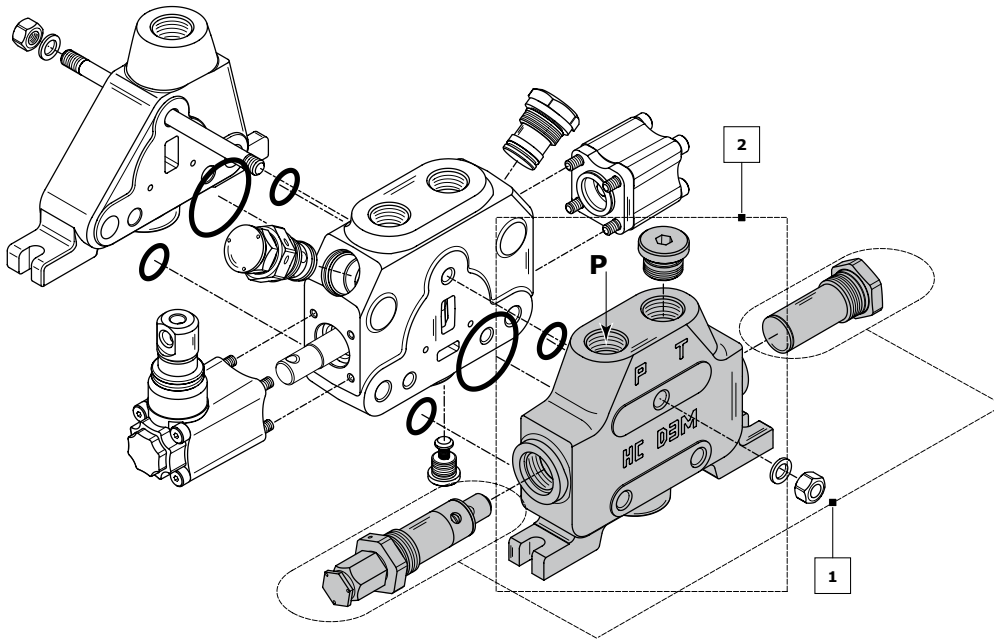

Rif.	Code	Description	Page
-	IR	Sectional valve with right inlet section	11
	IL	Sectional valve with left inlet section	
1	001	Direct acting pressure relief valve	12
	002	Direct acting pressure relief valve and Main anticavitation check valve	
	004	Direct acting pressure relief valve and Solenoid dump valve 12 Vdc	
	005	Direct acting pressure relief valve and Solenoid dump valve 24 Vdc	
	009	Pilot operated pressure relief valve	
	010	Pilot operated pressure relief valve and Main anticavitation check valve	
	012	Pilot operated pressure relief valve and Solenoid dump valve 12 Vdc	
	013	Pilot operated pressure relief valve and Solenoid dump valve 24 Vdc	
	019	without valves	
	020	Main anticavitation check valve	
2	A G04	Upper inlet (thread G 1/2)	13
	E G04	Upper inlet (inlet-outlet) (thread G 1/2)	
	A U03	Upper inlet (thread 3/4" - 16 UNF)	
	E U03	Upper inlet (inlet-outlet) (thread 3/4" - 16 UNF)	

NOTE: when ordering a relief valve it is necessary to specify factory setting (example 150).



Inlet side classifications

	Sectional valve with right inlet section	Sectional valve with right inlet section
IR	 	IL

Valve identification

NOTA: hydraulic lock or brake valve (valve type 10) needs special inlet section.

type	schema	layout	description	type	schema	layout	description
1			Direct acting pressure relief valve	6			Externally piloted dump valve
2			Pilot operated pressure relief valve	7			Solenoid dump valve 12 Vdc
3			Relief valve plugged	8			Solenoid dump valve 24 Vdc
4			Main anticavitation check valve	10			Hydraulic lock or brake valve
5			2 stage pilot operated relief valve	11			Plug with pressure-gauge connection



Valve arrangement

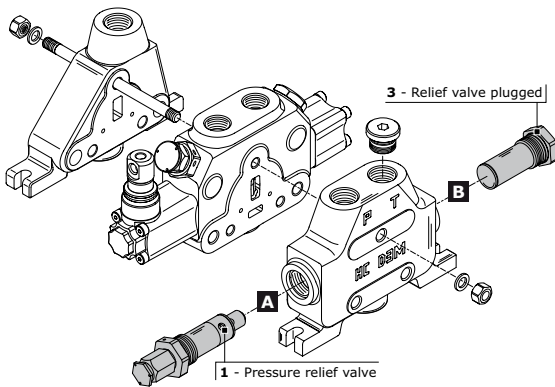

Combination valve example: 001 = 1A - 3B

- 001 Combination valve
- 1A Pressure relief valve in port A
- 3B Relief valve plugged in port B

The code identifies:
with a number, the type of valve; with a letter its position on the inlet section.

- (A) = spool action side
- (B) = spool return action side

NOTE: when ordering a main relief valve it is necessary to specify setting

VALVE COMBINATION INLET SECTION		Valve type on port B									
		1	2	3	4	5	6	7	8	10	11
Valve type on port A	1			001	002		003	004	005	007	008
	2			009	010		011	012	013	015	016
	3	017	018	019	020	021	022	023	024	026	027
	4	028	029	030			032			036	
	5			038							
	6	046	047	048	049						
	7	053	054	055							
	8	060	061	062							
	10	074	075	076	077						
	11	084	085	086							

NOTE: Valve combinations 021, and 038 requires double setting (see example).

Order example for inlet section: IR 038 200*280 A G04

038
200*380

valve combination _____
double range setting (bar) _____

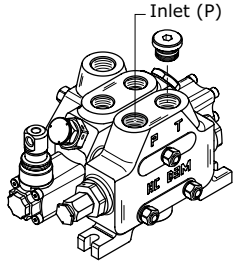
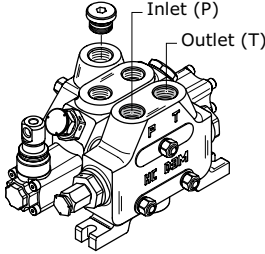

Inlet position and available thread type

Inlet combination and thread available	
A G04	
A U03	
E G04	
E U03	

NOTE: code E on inlet section obliges to choice E or W on outlet section.



WORKING SECTION

Order example:

W001A	H001	F001A	RP G04	01 PA 100	05 PB
-------	------	-------	--------	-----------	-------

- | | |
|--|--|
| <ol style="list-style-type: none"> 1. W001A 2. H001 3. F001A 4. RP G04 5. 01 PA 100 6. 05 PB | spool type _____
spool actuation type _____
spool return action type _____
section and thread type _____
auxiliary valve (port A - handle side) _____
auxiliary valve (port B - cap side) _____ |
|--|--|

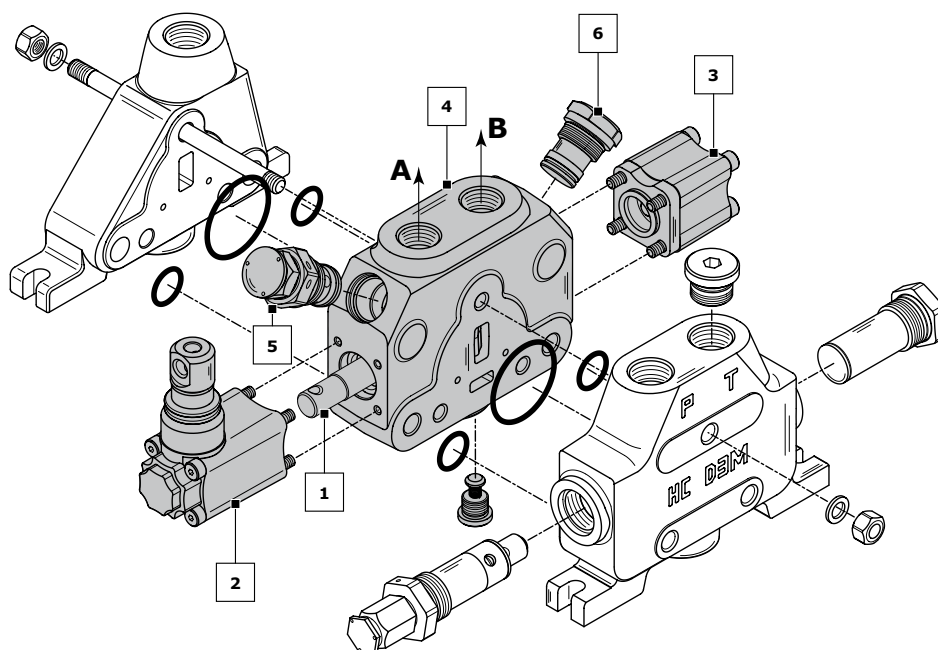

Rif.	Code	Description	Page
1	W001	3 positions double-acting	15
	W002	3 positions double-acting A-B to tank	
2	H001	Protected lever	17
	H005	hydraulic actuation	
3	F001A	3 positions spring-centred spool (spring A)	20
	F002A	3 positions spring-centred spool detent in A and B (spring A)	
4	RP G04	Parallel circuit (G 1/2)	28
	RP U03	Parallel circuit (3/4"-16 UNF)	
	RT G04	Parallel-Tandem circuit (G 1/2)	
	RT U03	Parallel-Tandem circuit (3/4"-16 UNF)	
5	01 PA 100	Antishock valve (port A)	29
	05 PA	Prearrangement for auxiliary valve (port A)	
6	01 PB 100	Antishock valve (port B)	29
	05 PB	Prearrangement for auxiliary valve (port B)	

NOTE: (*) Leave out the spool return action code when choosing H005.
 Sections designed to house auxiliary valve option require double choice on work ports A and B.
 Always indicate setting value when using antishock and combined valve: **01 PA (100) - 03 PA (120)**



Spool identification

order example of spool: **W001 A J10**

W001 spool schema 3 positions double-acting
A spool type standard spool
J10 restricted service ports restriction on diameter (0,10 mm in A and B)

W001	3 positions double-acting	
W002	3 positions double-acting A and B to tank	
W003	3 positions double-acting A to tank B blocked	
W004	3 positions double-acting A blocked B to tank	
W005	3 positions single - acting on A	
W006	3 positions single - acting on B	
W009	3 positions double-acting with anticavitation valves	
W010	3 positions double-acting switch port closed (A - B blocked)	
W011	3 positions double-acting switch port closed (A - B to tank)	
W012	4 positions double-acting with float in the 4th position	
W013	3 positions double-acting regenerative	
W015	3 positions double-acting series	
W016	3 positions double-acting series A and B to tank	



spools with restricted service ports				
code	circuit	restriction on diameter (mm)	section (mm ²)	hydraulic schema
J10	A-B IN T	0,10	2,66	
K10	A IN T	0,10	2,66	
Y10	B IN T	0,10	2,66	

CODE	spool type available		
	STANDARD	METERED	SOLENOID OPERATED
	A	B	E
W001	W001A	W001B	W001E
W002	W002A	W002B	W002E
W003	W003A	W003B	
W004	W004A	W004B	
W005	W005A	W005B	
W006	W006A	W006B	
W009	W009A	W009B	
W010	W010A		
W011	W011A		
W012	W012A		
W013	W013A		
W015	W015A		
W016	W016A		

NOTE:

- W012, W013, spools need a special machining on the valve body.
- W015, W016, spools need RS type body. Float spool (W012) need special detent kit (F005).
- Regenerative spool (W013) need special return spring kits.
- W001E and W002E spools are available only with Direct electric control (code H036 or H037).
- Different spools are available on request.

Please contact our Sales department for more information.



Spool actuation classification for manual control

code	description	dimensions	configuration
H001	Protected lever		
H002	Protected lever rotated 180°		
H004	Control without lever		
H019	Protected lever with stroke limiter		
H020	Protected lever with stroke limiter rotated 180°		

Spool actuation classification for Hydraulic control

code	description	dimensions	configuration
H005 <small>leave out the spool return action code</small>	Hydraulic actuation with side ports BSP ports = G 1/4 UNF ports = 9/16-18 UNF		

Hydraulic pilot control curve

The diagram shows the spool stroke as a function of the pressure operating.

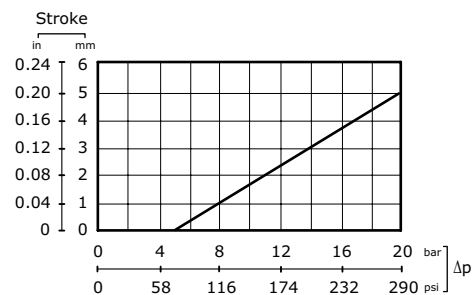

Direct electrical control classification

code	description	dimensions	configuration
H021 <small>only for spool return action code: F0150-F0160</small>	Direct electric control		
H022 <small>only for spool return action code: F0150-F0160</small>	Direct electric control rotated 180°		

NOTE:

the direct electric control use a type "E" special spool and a type "RPE" special body. Is available the Direct electric control without lever (code H024).



Direct electrical control classification

The ON-OFF electric control D3M control valve is suitable for all mobile applications and in particular for agricultural harvesting machines, gardening machines and small-sized dumpers. This actuation system is also recommended for earth moving and lifting machinery applications; in particular, it enables to remote-control truck mounted crane and aerial platform stabilizers.

code	description	dimensions
H036 leave out the spool return action code	Direct electric control 12 Vdc (45W - 3 A)	
H037 leave out the spool return action code	Direct electric control 24 Vdc (45W - 1,5 A)	

Direct electric control specifications

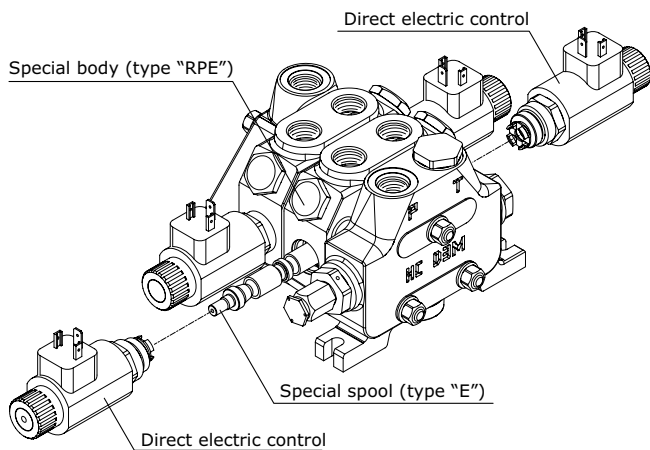

Type	HC-D3M	
Rated voltage	12 VDC	24 VDC
Rated current	3 A	1,5 A
Rated power	36 W	
Permitted working voltage	±10% Nominal	
Max ambient temperature	+40°C	
Max oil temperature	+80°C	
Operation time	S1 (100%)	
Protection degree	IP65	
Insulation degree	H	
Standard connector	DIN 43650	
Spool stroke	2,8 + 2,8 mm	

The H036 and H037 direct electric controls come as two kits each including a: coil, spring, solenoid and adapter. The H036 and H037 electric controls use a type E special spool and a type special body. The ON-OFF Electric Control kit includes a manually operated emergency push-button.

Operating limit curve

Data detected after voltage decrease equal to 28% of the rated value (conditions occurring with coil under stabilization temperature conditions with rated voltage reduced by 10%).

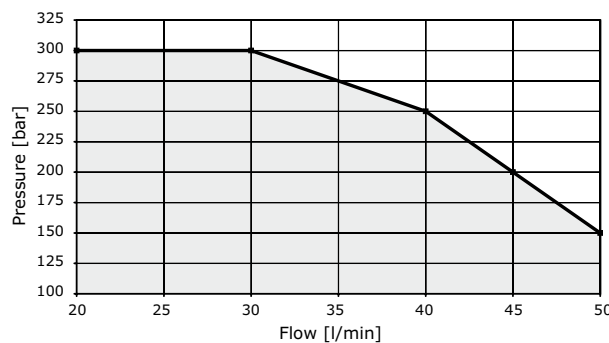



Joystick control classification

The configuration of joystick control interests always two working sections with relative four ports: **A1 – B1 – A2 – B2.**

For convention:

- section 1 is the first invested from the flow of the oil: it depends from the right or left inlet of the control valve
- Port A = spool action side
- Port B = spool return action side

The position of the fulcrum is identified by a code and stands in four configurations as shown in the following table:

Fulcrum Inlet side	FULCRUM 1 st section	FULCRUM 2 nd section
RIGHT INLET	<p>H009</p> <p>Right side inlet fulcrum on 1st section (compulsory code for second section: H120)</p>	<p>H010</p> <p>Right side inlet fulcrum on 2nd section (compulsory code for first section: H120)</p>
	<p>H011</p> <p>Left side inlet fulcrum on 1st section (compulsory code for second section: H120)</p>	<p>H012</p> <p>Left side inlet fulcrum on 2nd section (compulsory code for first section: H120)</p>

The second section concerned the configuration of the joystick control is always identified with code H120. Lever has to be ordered separately.



Spool return action classification - Springs load values

Spool return kits have three different spring types; following the codes depending on spring loads.

Spring type			
Code	A (standard spring)	B (soft spring)	C (heavy spring)
Preloading	121.6 N	88.3 N	149.1 N
End of stroke	203 N	147.1 N	206 N
Spool return action identification example			
Code	F001A	F001B	F001C

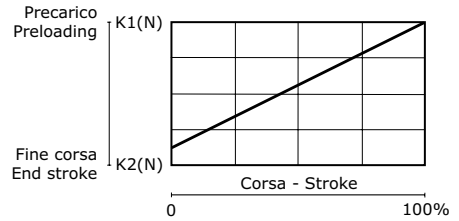

Spool return action classification

code	description	schema	dimensions	configuration
F001A F001B F001C	3 positions spring-centred spool			
F002A	3 positions spring-centred spool detent in A and B			
F003A	3 positions spring-centred spool detent in A			
F004A	3 positions spring-centred spool detent in B			
F005A	4 positions spring-centred spool detent in 4 th position (only for W012 spool)			



Spool return action classification

code	description	schema	dimensions	configuration
F009A F009B F009C	2 positions in A spring-centred spool			
F010A F010B F010C	2 positions in B spring-centred spool			
F011A F011B F011C	2 positions detent in A spring-centred spool			
F012A F012B F012C	2 positions detent in B spring-centred spool			
F013A F013B F013C	3 positions spring-centred spool prearrangement dual command			

Direct electrical control identification

It allows for the remote activation on the valve through the use of electrical on/off switches.

Available voltages: 12V and 24V. Need a special machining on the valve body. Available just with spool W001E.

code	description	dimensions	configuration
F0150 <small>only for spool actuation code: H021 H022-H024</small>	Direct electrical control (PUSH-PULL) 12 vdc (60 W - 5 A)		
F0160 <small>only for spool actuation code: H021 H022-H024</small>	Direct electrical control (PUSH-PULL) 24 vdc (60 W - 2,5 A)		



Pneumatic control classification

code	description	schema	dimensions	configuration
F020A	Pneumatic control ON - OFF		<p>Proportional control with port BSP: G 1/8</p>	
F021A	Pneumatic control ON - OFF rotated 180°			
F022A	Proportional Pneumatic control		<p>Proportional control with port NPTF: 1/8-27</p>	
F023A	Proportional Pneumatic control rotated 180°			
F135A	Pneumatic control ON - OFF		<p>Proportional control with port NPTF: 1/8-27</p>	
F136A	Pneumatic control ON - OFF rotated 180°			
F126A	Proportional Pneumatic control		<p>Proportional control with port NPTF: 1/8-27</p>	
F127A	Proportional Pneumatic control rotated 180°			

Proportional pneumatic control curve

The diagram shows the spool stroke as a function of the pneumatic pressure operating.

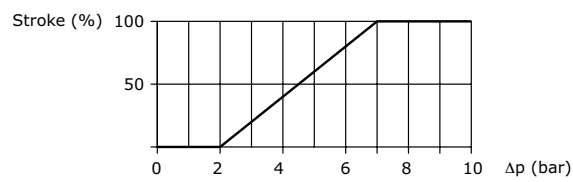



Electropneumatic control classification

code	description	dimensions	configuration
F0620	3 positions electropneumatic control ON-OFF (12 vdc) 7 W - 0,58 A		
F0630	3 positions electropneumatic control ON-OFF (24 vdc) 7 W - 0,29 A		

Minimum
working
pressure
5 bar

Control tie rod assembly

The length of the control tie rod, will change depending on the section numbers; in this way it will be easy to install in the right way the sections and avoid any misassembly. Each kit is composed by 1 tie rod and 2 plugs.

NOTE: the control tie rod kit has always to be ordered separately.

Order code for control tie rod (BSP):

- 320103013** = control tie rod /1
- 320103014** = control tie rod /2
- 320103015** = control tie rod /3
- 320103016** = control tie rod /4
- 320103017** = control tie rod /5
- 320103018** = control tie rod /6
- 320103019** = control tie rod /7
- 320103020** = control tie rod /8

Order code for control tie rod (UNF):

- 320103038** = control tie rod /1
- 320103039** = control tie rod /2
- 320103040** = control tie rod /3
- 320103041** = control tie rod /4
- 320103042** = control tie rod /5
- 320103043** = control tie rod /6
- 320103044** = control tie rod /7
- 320103045** = control tie rod /8

Load limit classification

code	description	schema	dimensions	configuration
F024A F024C	Load limit in A and B			
F025A F025C	Load limit in A and B rotated 180°			
F026A F026C	Load limit in A			
F027A F027C	Load limit in A rotated 180°			
F028A F028C	Load limit in B			
F029A F029C	Load limit in B rotated 180°			

NOTE: on request is available the load limit with dual control; for more informations please contact our Commercial Dept.



Electrical load limit kit identification

Spool position sensor			
Power supply	Contacts capacity	Protection degree	temperature range
12 vdc	3 A	IP 65	da -25°C a +90°C
24 vdc	1,5 A		

Operational diagram

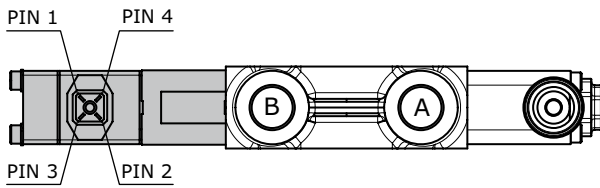

CONTROL in A e B = connect PIN 1 - 4 and 2 - 3
CONTROL in A = connect PIN 2 - 3
CONTROL in B = connect PIN 1 - 4

Wiring diagram

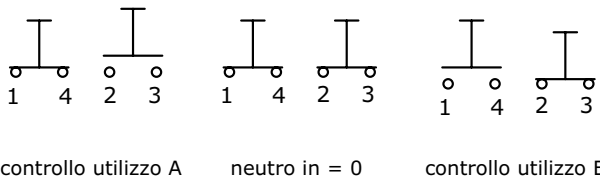

In case of inductive loads it is advisable to connect the terminals of the workport (solenoid) to a 200 VDC - 3A diode.

code	description	dimensions	configuration
F0360	Electrical load limit (normally closed contacts)		
F0370	Electrical load limit rotated 180° (normally closed contacts)		
F0450	Electrical load limit (normally open contacts)		
F0460	Electrical load limit rotated 180° (normally open contacts)		

NOTE: a HIRSCHMANN female connector, type G4 W1F, is available on request (code 413000045, to be ordered separately).



Electrohydraulic control specifications

Operating temperature range	-20°C / +80°C
Max inlet pressure	350 bar
Reduced pressure	16 bar
Back pressure on (T)	3 bar
Filtering degree	25 μ assoluti
Raccommended pilot pipe size	Ø 6 mm - G 1/4

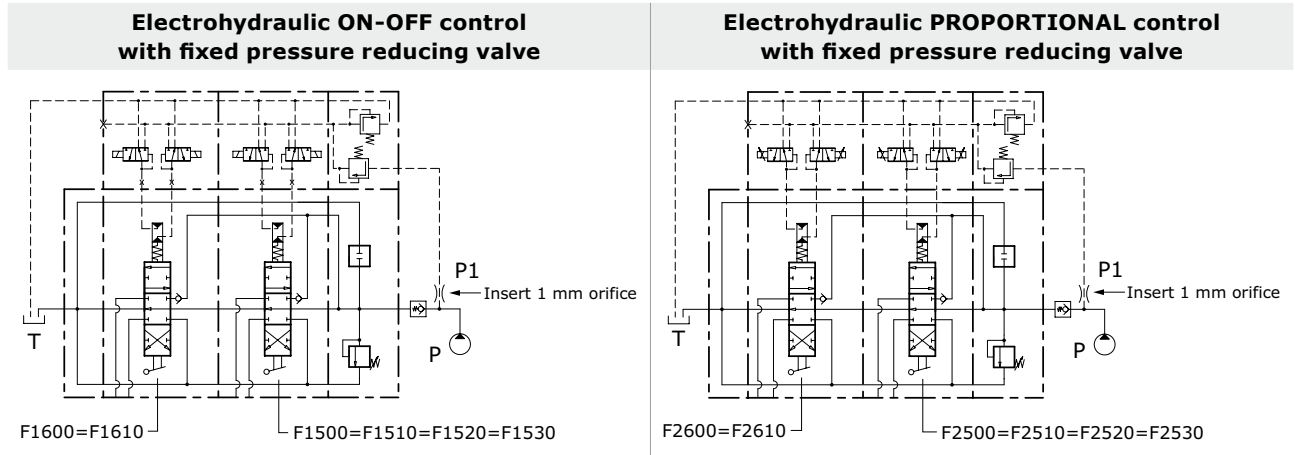

Proportional control kit, mechanically retrooperated, allows the maximum precision of positioning, limiting the hysteresis. The control is operated with PWM control of the current. PWM frequency suggest: 60-80 Hz

Nominal voltage (V)	regulation currents		
	Resistance R ₂₀ (Ohm)	Current min (A)	Current max (A)
12 vdc	3,7	0,9	1,7
24 vdc	15,5	0,45	0,85

Electrohydraulic control classification

code	description	dimensions	configuration
F1600	3 positions electrohydraulic control ON - OFF 12 Vdc		
F1610	3 positions electrohydraulic control ON - OFF 24 Vdc		
F2600	3 positions electrohydraulic control PROPORTIONAL 12 Vdc		
F2610	3 positions electrohydraulic control PROPORTIONAL 24 Vdc		

Electrohydraulic ON-OFF control is stackable with electrohydraulic PROPORTIONAL control (F2600 = F2610). Control kit already includes orifice to make spool displacement more gradual.

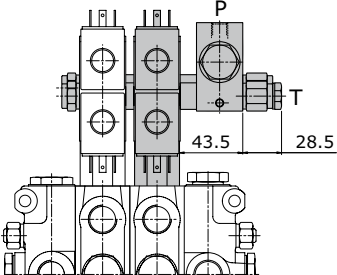
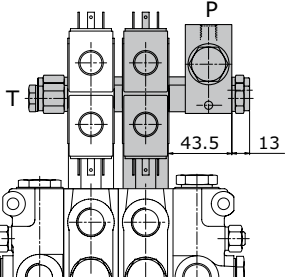

Electrohydraulic control with fixed pressure reducing valve classification

code	description	configuration
F1500	Electrohydraulic control ON - OFF (fixed pressure reducing valve) P - T inlet side (12 vdc)	 <p>Port BSP (P - T) = G 1/4 Port UNF (P - T) = 9/16"18 UNF</p>
F1510	Electrohydraulic control ON - OFF (fixed pressure reducing valve) P - T inlet side (24 vdc)	
F2500	Electrohydraulic control PROPORTIONAL (fixed pressure reducing valve) P - T inlet side (12 vdc)	
F2510	Electrohydraulic control PROPORTIONAL (fixed pressure reducing valve) P - T inlet side (24 vdc)	
F1520	Electrohydraulic control ON - OFF (fixed pressure reducing valve) P inlet - T outlet (12 vdc)	 <p>Port BSP (P - T) = G 1/4 Port UNF (P - T) = 9/16"18 UNF</p>
F1530	Electrohydraulic control ON - OFF (fixed pressure reducing valve) P inlet - T outlet (24 vdc)	
F2520	Electrohydraulic control PROPORTIONAL (fixed pressure reducing valve) P inlet - T outlet (12 vdc)	
F2530	Electrohydraulic control PROPORTIONAL (fixed pressure reducing valve) P inlet - T outlet (24 vdc)	

Control tie rod assembly

The length of the control tie rod, will change depending on the section numbers; in this way it will be easy to install in the right way the sections and avoid any misassembly. Each kit is composed by 2 tie rods, 2 plugs, 2 connection ports and spacers according to the section number.

NOTE: the control tie rod kit has always to be ordered separately.
Reducing valve, combined with electrohydraulic control kit has to be calculated as a normal working section.

ORDER EXAMPLE:

Complete valves with 3 sections F1600 requires a complete tie-rod kit /3.
Complete valves with 2 sections F1600 and 1 section with F1500 (reducing valve) requires a complete tie-rod kit /4.

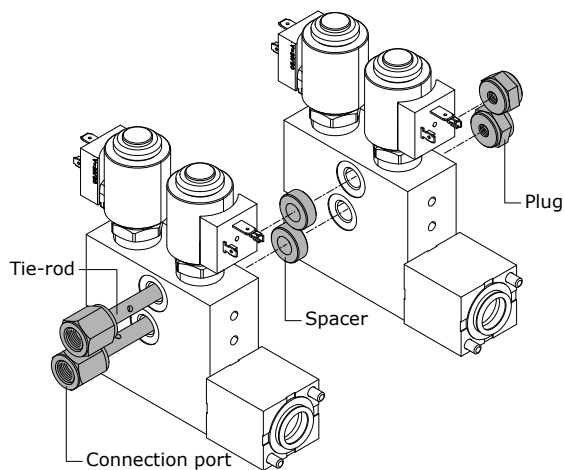

Order code fixed pressure reducing valve:

- 915000303** = reducing valve for BSP ports
- 915000312** = reducing valve for UNF ports

Order code for control tie rod (BSP):

- 320103001** = control tie rod /1
- 320103002** = control tie rod /2
- 320103003** = control tie rod /3
- 320103004** = control tie rod /4
- 320103005** = control tie rod /5
- 320103006** = control tie rod /6
- 320103007** = control tie rod /7
- 320103008** = control tie rod /8
- 320103009** = control tie rod /9

Order code for control tie rod (UNF):

- 320103026** = control tie rod /1
- 320103027** = control tie rod /2
- 320103028** = control tie rod /3
- 320103029** = control tie rod /4
- 320103030** = control tie rod /5
- 320103031** = control tie rod /6
- 320103032** = control tie rod /7
- 320103033** = control tie rod /8
- 320103034** = control tie rod /9



Compatibility table

SPOOL ACTION TYPE	SPOOL TYPE																						
	W001A	W001B	W001E	W002A	W002B	W002E	W003A	W003B	W004A	W004B	W005A	W005B	W006A	W006B	W009A	W009B	W010A	W011A	W012A	W013A	W015A	W016A	
H001	•	•		•	•		•	•	•	•	•	•	•	•	•	•	•	•	•	•	•	•	•
H002	•	•		•	•		•	•	•	•	•	•	•	•	•	•	•	•	•	•	•	•	•
H004	•	•		•	•		•	•	•	•	•	•	•	•	•	•	•	•	•	•	•	•	•
H005	•	•		•	•		•	•	•	•	•	•	•	•	•	•	•	•	•	•	•	•	•
H009	•	•		•	•		•	•	•	•					•	•				•	•	•	•
H010	•	•		•	•		•	•	•	•					•	•				•	•	•	•
H011	•	•		•	•		•	•	•	•					•	•				•	•	•	•
H012	•	•		•	•		•	•	•	•					•	•				•	•	•	•
H120	•	•		•	•		•	•	•	•					•	•				•	•	•	•
H019	•	•		•	•		•	•	•	•	•	•	•	•	•	•	•	•	•	•	•	•	•
H020	•	•		•	•		•	•	•	•	•	•	•	•	•	•	•	•	•	•	•	•	•
H021			•			•																	
H022			•			•																	
H036			•			•																	
H037			•			•																	
SPOOL RETURN ACTION TYPE	SPOOL TYPE																						
	W001A	W001B	W001E	W002A	W002B	W002E	W003A	W003B	W004A	W004B	W005A	W005B	W006A	W006B	W009A	W009B	W010A	W011A	W012A	W013A	W015A	W016A	
F001	•	•	•	•	•	•	•	•	•	•	•	•	•	•	•	•	•	•		•	•	•	•
F002	•	•	•	•	•	•	•	•	•	•	•	•	•	•	•	•	•	•				•	•
F003	•	•	•	•	•	•	•	•	•	•	•	•	•	•	•	•	•	•				•	•
F004	•	•	•	•	•	•	•	•	•	•	•	•	•	•	•	•	•	•				•	•
F005																			•				
F009	•	•	•	•	•	•	•	•	•	•					•	•	•	•				•	•
F010	•	•	•	•	•	•	•	•	•	•					•	•	•	•				•	•
F011	•	•	•	•	•	•	•	•	•	•					•	•	•	•				•	•
F012	•	•	•	•	•	•	•	•	•	•					•	•	•	•				•	•
F013	•	•	•	•	•	•	•	•	•	•	•	•	•	•	•	•	•	•			•	•	•
F020=F021	•	•	•	•	•	•	•	•	•	•	•	•	•	•	•	•	•	•			•	•	•
F022=F023	•	•	•	•	•	•	•	•	•	•	•	•	•	•	•	•	•	•			•	•	•
F135=F136	•	•	•	•	•	•	•	•	•	•	•	•	•	•	•	•	•	•			•	•	•
F126=F127	•	•	•	•	•	•	•	•	•	•	•	•	•	•	•	•	•	•			•	•	•
F024=F025	•	•	•	•	•	•	•	•	•	•					•	•	•	•				•	•
F026=F027	•	•	•	•	•	•	•	•	•	•					•	•	•	•				•	•
F028=F029	•	•	•	•	•	•	•	•	•	•					•	•	•	•				•	•
F0150			•			•																	
F0160			•			•																	
F0360=F0370	•	•	•	•	•	•	•	•	•	•	•	•	•	•	•	•	•	•				•	•
F0450=F0460	•	•	•	•	•	•	•	•	•	•	•	•	•	•	•	•	•	•				•	•
F0620=F0630	•	•	•	•	•	•	•	•	•	•					•	•	•	•			•	•	•
F1500=F1510	•	•	•	•	•	•	•	•	•	•	•	•	•	•	•	•	•	•			•	•	•
F1520=F1530	•	•	•	•	•	•	•	•	•	•	•	•	•	•	•	•	•	•			•	•	•
F2500=F2510	•	•	•	•	•	•	•	•	•	•	•	•	•	•	•	•	•	•			•	•	•
F2520=F2530	•	•	•	•	•	•	•	•	•	•	•	•	•	•	•	•	•	•			•	•	•
F1600=F1610	•	•	•	•	•	•	•	•	•	•	•	•	•	•	•	•	•	•			•	•	•
F2600=F2610	•	•	•	•	•	•	•	•	•	•	•	•	•	•	•	•	•	•			•	•	•



Work section identification

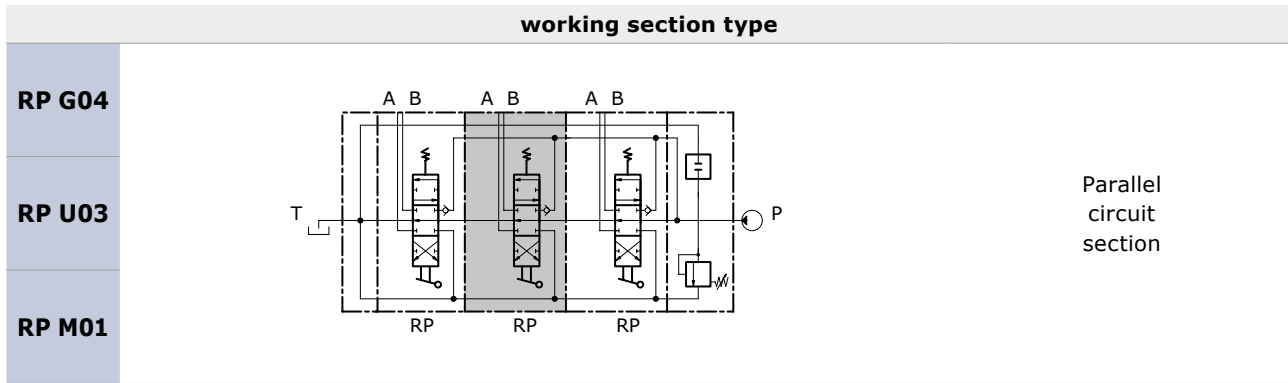

When the spool is operated it intercepts the by-pass gallery by diverting the flow of oil to service port A or B. If two or more spools are actuated at the same time, the oil will power the service port that has the lower load; by throttling the spools, the flow of oil can be divided between two or more service ports.

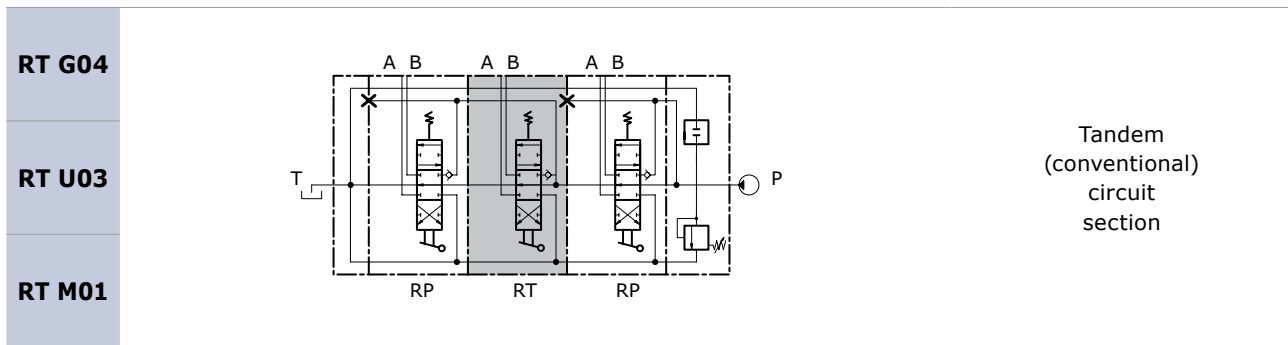

When the spool is operated it intercepts the switch gallery by diverting the flow of oil to service port A or B. The Tandem circuit is powered by the switch gallery thus permitting the use of just one work section at a time. The section downstream from the tandem section that has been actuated does not operate, the upstream section has priority.

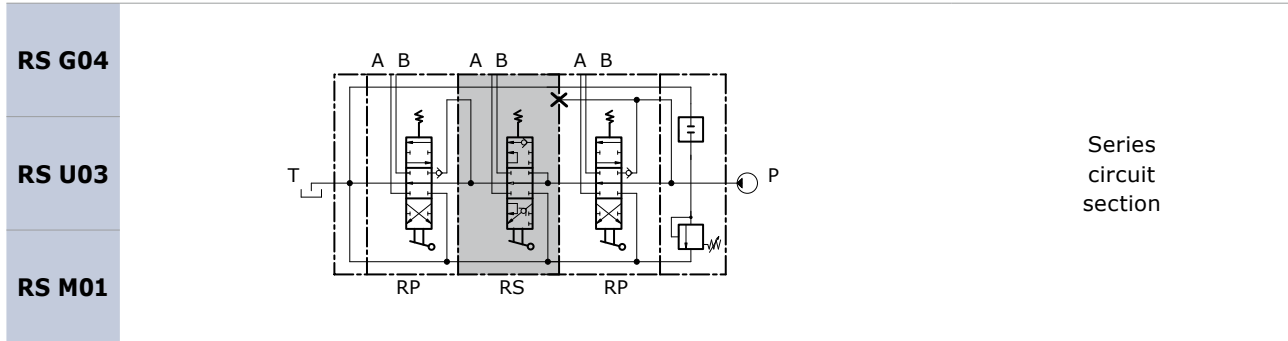

When the spool is operated it intercepts the switch gallery by diverting the flow of oil to service port A or B. The oil that flows back from the actuator is carried to the switch gallery thus making it available to the service ports downstream from the series section. The pressure drop downstream is added to the pressure drop of the section itself.



Auxiliary valve identification

code	description	schema	configuration	setting range (bar)			
				type	at full flow	type	at min. flow
01PA	Antishock valve (port A)			A	20 / 100	A	10-A / 80-A
				B	101 / 220	B	81-A / 180-A
				C	221 / 350	C	181-A / 350-A
02PA	Anticavitation valve (port A)						
03PA	Combined valve (port A)			A	20 / 60	A	10-A / 40-A
				B	61 / 100	B	41-A / 80-A
				C	101 / 220	C	81-A / 180-A
				D	221 / 350	D	181-A / 350-A
05PA	Prearrangement for auxiliary valve (port A)						

code	description	schema	configuration	setting range (bar)			
				type	at full flow	type	at min. flow
01PB	Antishock valve (port A)			A	20 / 100	A	10-A / 80-A
				B	101 / 220	B	81-A / 180-A
				C	221 / 350	C	181-A / 350-A
02PB	Anticavitation valve (port A)						
03PB	Combined valve (port A)			A	20 / 60	A	10-A / 40-A
				B	61 / 100	B	41-A / 80-A
				C	101 / 220	C	81-A / 180-A
				D	221 / 350	D	181-A / 350-A
05PB	Prearrangement for auxiliary valve (port A)						

Auxiliary valve - Setting range

Sections designed to house auxiliary valve option require double choice on work ports A and B.

Always indicate setting value when using antishock valve and combined valve:

01PA (120) = setting at full flow

01PA (120-A) = setting at min. flow



INTERMEDIATE INLET SECTION

Order example

BE	009	150	A G04
----	-----	-----	-------

1. **BE** inlet side _____
2. **009** valve arrangement _____
3. **150** setting (bar); when ordering a main relief valve it is necessary to specify setting _____
3. **A G04** inlet position and available thread type _____

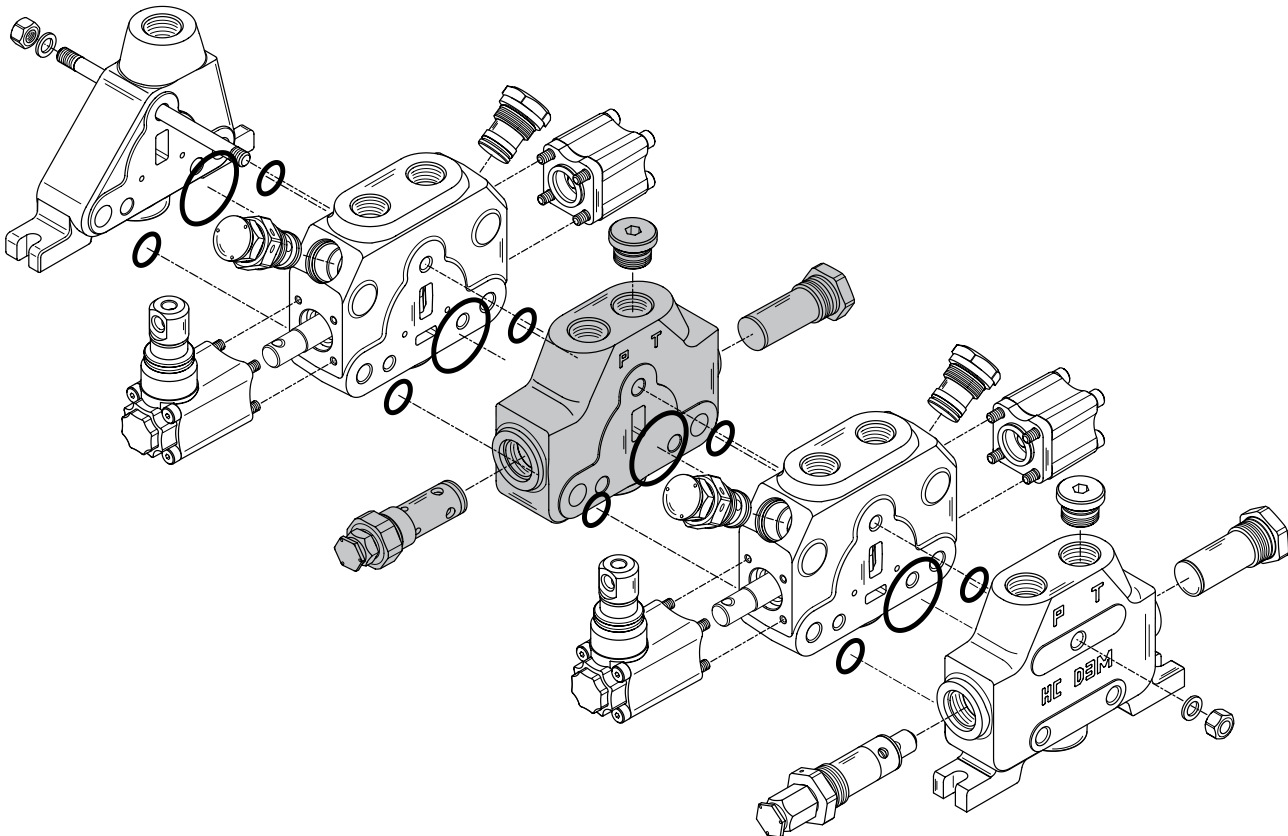

Rif.	Code	Description	Page
-	BE	Intermediate inlet section	31
-	BV*	Intermediate inlet section with pressure relief valve	
1	001	Direct acting pressure relief valve	32
	002	Direct acting pressure relief valve and Main anticavitation check valve	
	009	Pilot operated pressure relief valve	
	020	Main anticavitation check valve	
2	A G04	Upper inlet (thread G 1/2)	
	A U03	Upper inlet (thread 3/4"-16 UNF)	
	A U04	Upper inlet (thread 7/8" - 14 UNF)	
	A M01	Upper inlet (thread M18 x 1.5)	

NOTE: when ordering a relief valve it is necessary to specify factory setting (example 150).

* = omit the code for inlet positioning and thread



Intermediate inlet section classifications

intermediate inlet type

BE			Intermediate inlet section
-----------	--	--	----------------------------

The intermediate inlet section is driven by two pumps (P + P1). The downstream elements can be set to a lower pressure than the upstream ones by adjusting the pressure relief valve of the intermediate section in question.

BV			Intermediate inlet section with pressure relief valve
-----------	--	--	---

The intermediate inlet section and the elements are driven by a single pump (P). The downstream elements can be set to a lower pressure than the upstream ones by adjusting the pressure relief valve of the intermediate section in question.

Valve identification on intermediate inlet section

type	schema	layout	description	type	schema	configurazione	descrizione
1			Direct acting pressure relief valve	4			Externally piloted valve
2			Pilot operated pressure relief valve	11			Plug with pressure-gauge connection
3			Relief valve plugged				

Valve arrangement on intermediate inlet section

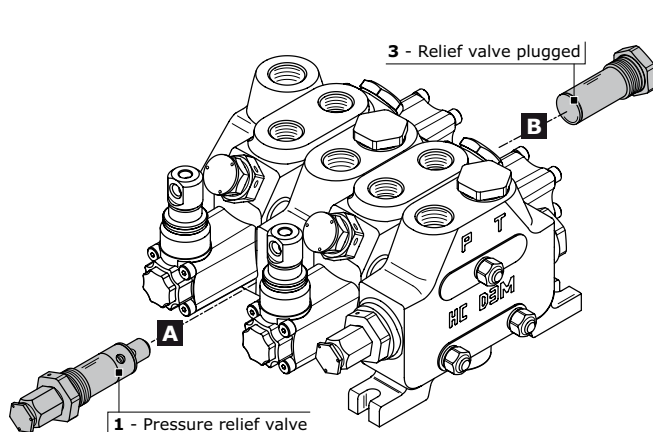

Combination valve example: 009 = 2A - 3B











- 009** Combination valve
- 2A** Pressure relief valve in port A
- 3B** Relief valve plugged in port B

The code identifies:
with a number, the type of valve; with a letter its position on the inlet section.

- (A) = spool action side
- (B) = spool return action side

NOTE: when ordering a main relief valve it is necessary to specify setting



VALVE COMBINATION INLET SECTION		Valve type on port B				
		 1	 2	 3	 4	 11
Valve type on port A	 1			001	002	008
	 2			009	010	016
	 3	017	018	019	020	027
	 4	028	029	030		
	 11	084	085	086		

Inlet position and available thread type

Inlet combination and thread available

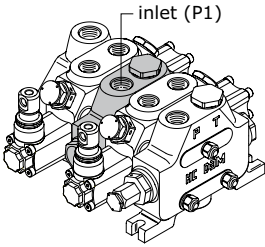
A G04		Upper inlet (P1)
A U03		
A U04		
A M01		

Complete configuration samples for D3M/2 with intermediate inlet section (BE)

- IR 001 150 A G04..... Right inlet section
- W001A H001 F001A RP G04 Working section
- BE 009 150 A G04Intermediate inlet section**
- W001A H001 F001A RP G04 Working section
- TJ A G04 Outlet section

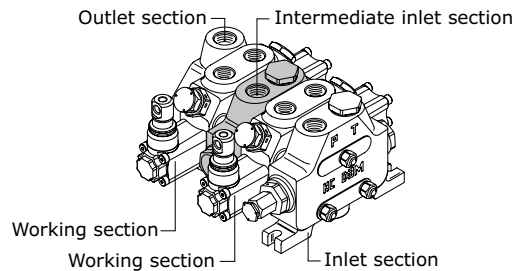

Complete configuration samples for D3M/2 with intermediate inlet section (BV)

- IR 001 150 A G04..... Right inlet section
- W001A H001 F001A RP G04 Working section
- BV 009 150Intermediate inlet section**
- W001A H001 F001A RP G04 Working section
- TJ A G04 Outlet section

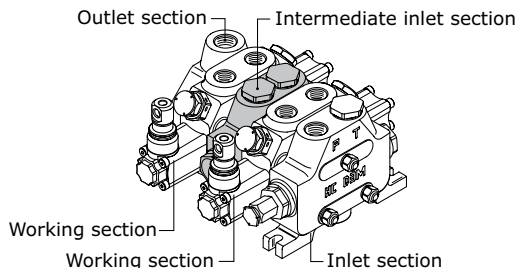



INTERMEDIATE OUTLET SECTION

Order example

BF | **A G04**

1. **BF** inlet side _____
A G04 inlet position and available thread type _____

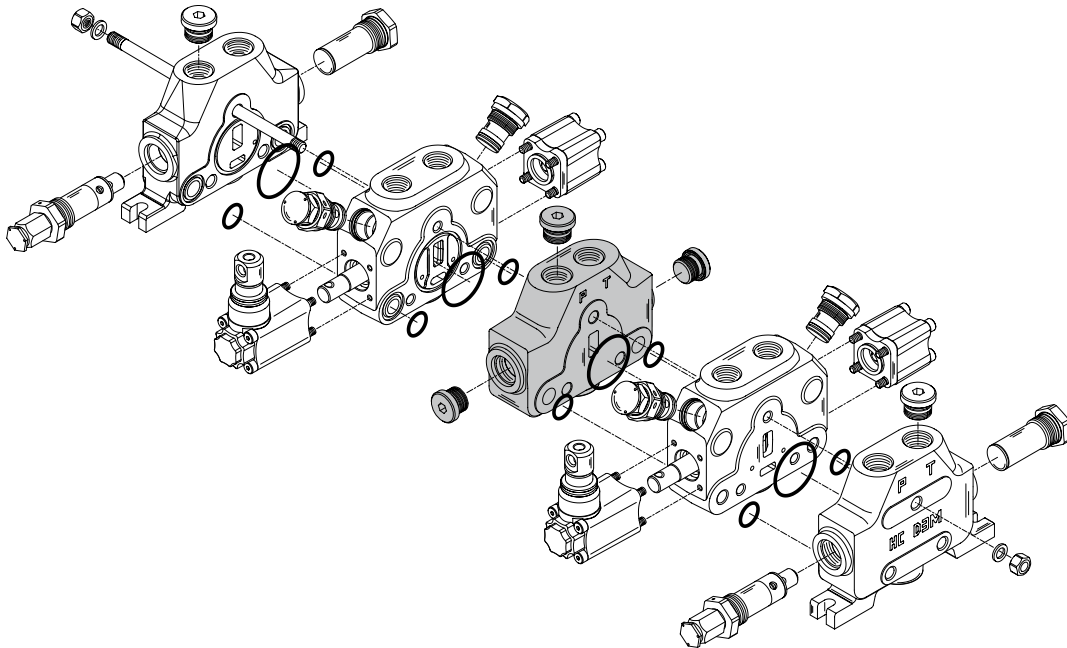

Rif.	Code	Type	Description	Page
-	BF		Intermediate outlet section with single tank return	
-	BG		Intermediate outlet section with two tank returns	
1	A G04		Upper outlet (thread G 1/2)	34
	A U03		Upper outlet (thread 3/4"-16 UNF)	
	G G04	for	Front outlet side A (thread G 1/2)	
	G U03	BF	Front outlet side A (thread 3/4"-16 UNF)	
	H G04		Rear outlet side B (thread G 1/2)	
	H U03		Rear outlet side B (thread 3/4"-16 UNF)	
	J G04	for	Upper outlet HPCO - front side A and rear side B to T (thread G 1/2)	
	J U03	BG	Upper outlet HPCO - front side A and rear side B to T (thread 7/8"-16 UNF)	



intermediate outlet classification

BF			Intermediate outlet section with single tank return
-----------	--	--	---

The above outlet section allows the flow of oil of the two pumps and the tank ports to be piped to a single outlet T.

BG			Intermediate outlet section with two tank returns
-----------	--	--	---

The section in question allows the flow of oil of the two pumps to be piped in two outlets: HPCO for powering another directional control valve, T for discharge of the work ports. In order to obtain this, the two T need to be linked.

Outlet combination and thread available

A G04		available only for BF	Upper outlet (T)
A G05			
A U03			
A U04			
A M02			
G G04		available only for BF	Front outlet side A (T)
G U03			
G U04			
G M02			
H G04		available only for BF	Rear outlet side B (T)
H U03			
H U04			
H M02			
J G04		available only for BG	Upper outlet HPCO front side A and rear side B to T
J U03			
J U04			
J M02			



Complete configuration samples for D3M/2 with intermediate outlet section (BF)

IR 001 150 A G04..... Right inlet section

W001A H001 F001A RP G04 Working section

BF A G05Intermediate outlet section

W001A H001 F001A RP G04 Working section

IL 009 150 A G04..... Left inlet section

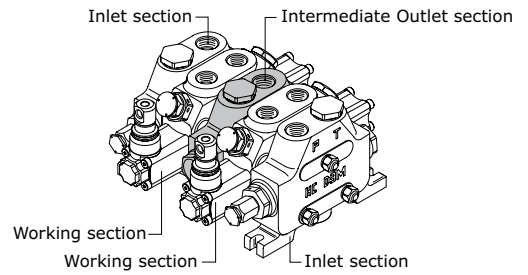

Complete configuration samples for D3M/2 with intermediate outlet section (BG)

IR 001 150 A G04..... Right inlet section

W001A H001 F001A RP G04 Working section

BG J G04Intermediate outlet section

W001A H001 F001A RP G04 Working section

IL 009 150 A G04..... Left inlet section

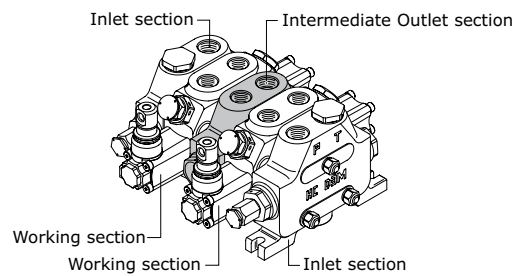



OUTLET SECTION (VERSION 1 OUTLET)

Order example

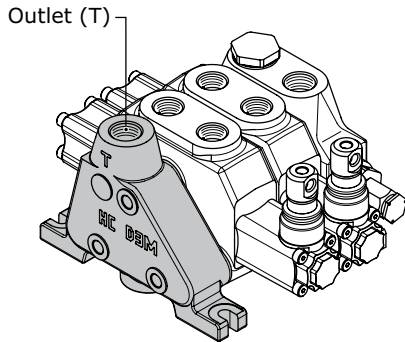

TJ | **A G04**

1. **TJ** outlet section type
2. **A G04** outlet position and available thread type

Rif.	Code	Description	Page
1	TJ	Outlet section with single return (T) right-side inlet (P)	
	TK	Outlet section with single return (T) left-side inlet (P)	
2	A G04	Upper outlet (thread G 1/2)	37
	C G04	Central outlet (thread G 1/2)	
	A U04	Upper outlet (thread 7/8" - 14 UNF)	
	C U04	Central outlet (thread 7/8" - 14 UNF)	

OUTLET SECTION (HPCO VERSION OUTLET)

Order example - HPCO version Outlet

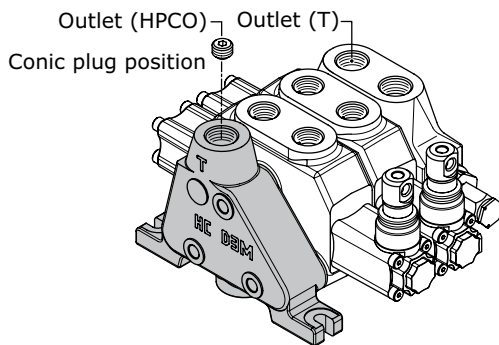

TM | **M G04**

1. **TM** outlet section type
2. **W G04** outlet position and available thread type

Rif.	Code	Description	Page
1	TM	Outlet section with two return (T-HPCO) right-side inlet (P)	
	TN	Outlet section with two return (T-HPCO) left-side inlet (P)	
2	W G04	HPCO Upper inlet - outlet T (tank) upper outlet section (thread G 1/2)	38
	W U03	HPCO Upper inlet - outlet T (tank) upper outlet section (thread 3/4" - 16 UNF)	



Outlet with single tank classification

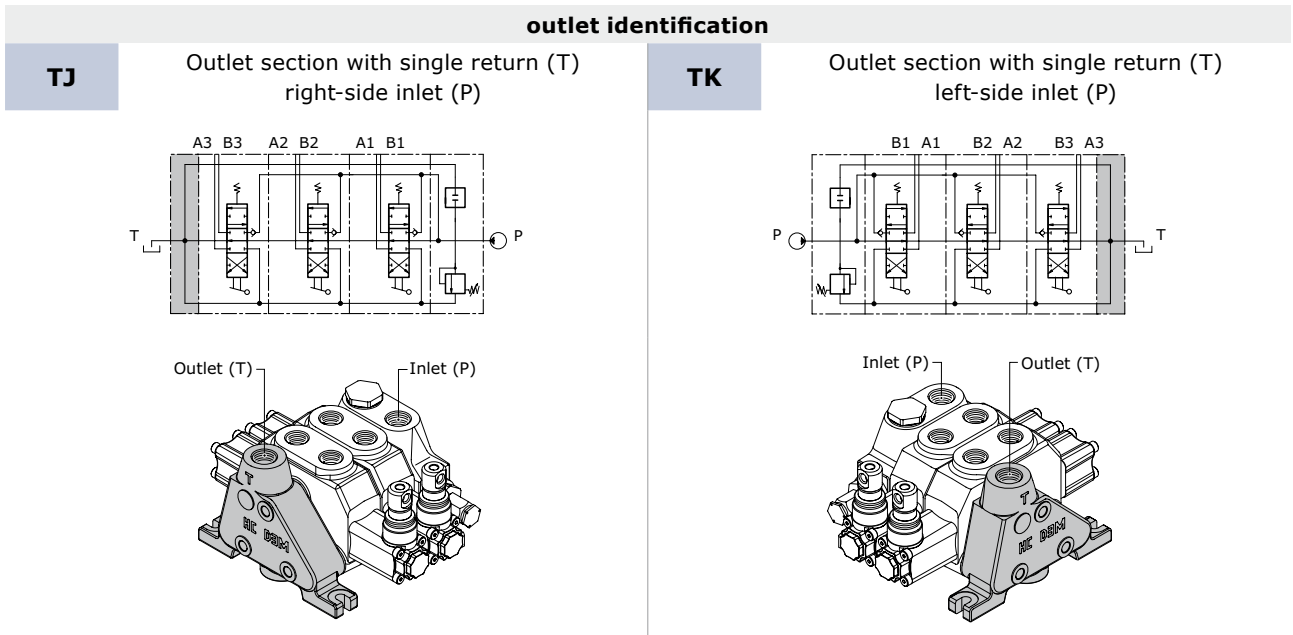

outlet combination and thread available

A G04		Upper outlet (thread G 1/2)
A U03		Upper outlet (thread 3/4" - 16 UNF)
A M02		Upper outlet (thread M22 x 1,5)
E G04		Upper outlet (inlet - outlet) (thread G 1/2)
E U03		Upper outlet (inlet - outlet) (thread 3/4" - 16 UNF)
E M02		Upper outlet (inlet - outlet) (thread M22 x 1,5)

NOTE: code "E" on outlet section obliges to choice "E" on inlet section.



Outlet with two tanks classification

outlet identification

TM

Outlet section with two return (T-HPCO) right-side inlet (P)

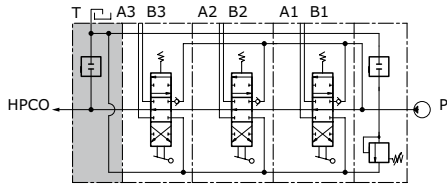

Outlet (HPCO) Outlet (T) Inlet (P)
Conic plug position

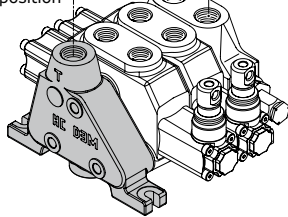

TN

Outlet section with two return (T-HPCO) left-side inlet (P)

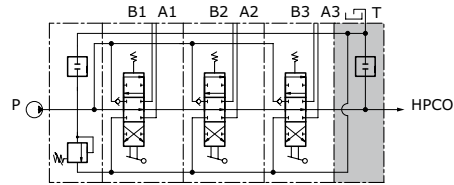

Inlet (P) Outlet (HPCO)
Outlet (T) Conic plug position

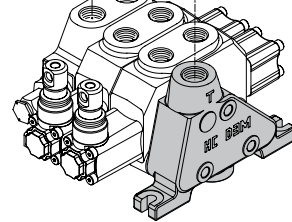

outlet combination and thread available

W G04

Outlet (HPCO) Outlet (T)

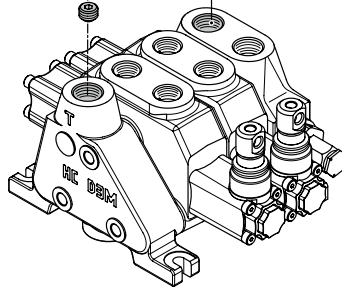

HPCO Upper inlet - outlet
T (tank) upper outlet section
(thread G 1/2)

W U03

HPCO Upper inlet - outlet
T (tank) upper outlet section
(thread 3/4" - 16 UNF)

NOTE: code "W" on outlet section obliges to choice "E" on inlet section.



Carry-over connection (HPCO)

This option, available on all D3M, allows the sectional valve to feed a second valve, by extending the free flow channel. In this configuration, the valve need a separated port for connection to tank.

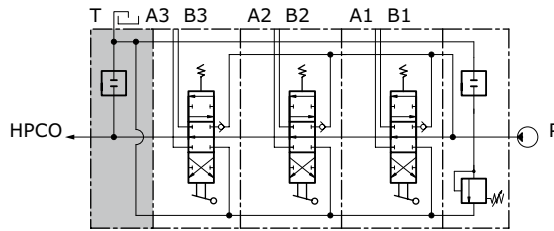

It is possible to transform sectional valve from standard to HPCO version just by ordering the appropriate conic plug:

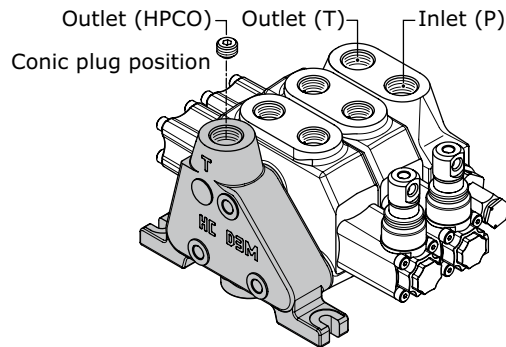

code (HPCO Plug identification)	description	q.ty
413010203	conic plug G 1/4 x 13	1



D3M SPARE PARTS LIST

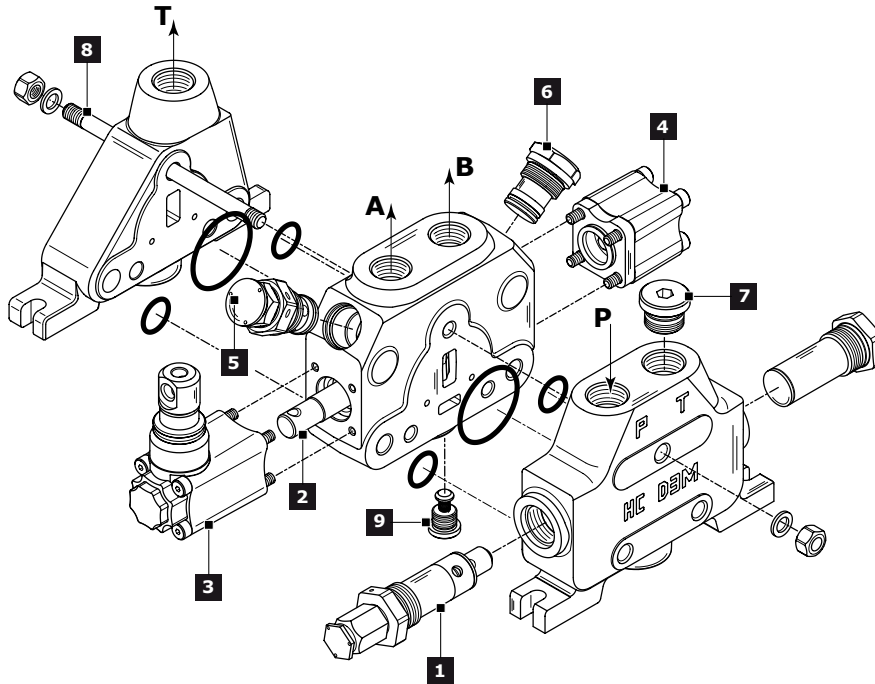

Ref.	Description	Order code	Q.ty	Code	Note
1	Direct acting pressure relief valve (*)	81451			Setting: 100 bar
		2723	1	-	Setting: 200 bar
		5371			Setting: 300 bar
		48734			Setting: 100 bar
	Pilot operated pressure relief valve (*)	4480	1	-	Setting: 200 bar
		7383			Setting: 300 bar
		Relief valve plugged	430104001	1	
	Main Anticavitation check valve	915050401	1		
External piloted valve	915040405	1			
Solenoid dump valve (12 vdc) (**)	915040402	1			
Solenoid dump valve (24 vdc) (**)	915040403	1			
Hydraulic lock or brake valve	915000401	1			
Plug with pressure-gauge connection	430104002	1			
2	3 positions double-acting spool	421203169		W001A	for protected lever
		421203021		W001B	for protected lever
		421203122		W001A	for without lever
		421203124	1	W001B	for without lever
		421203001		W001A	for hydraulic actuation
		411203148		W001E	for direct electrical control
	3 positions double-acting A and B to tank spool	411203149			for H036 = H037 control
		421203171		W002A	for protected lever
		421203026		W002B	for protected lever
		421203039	1	W002A	for without lever
		421203060		W002B	for without lever
		421203002		W002A	for hydraulic actuation
	3 positions single-acting on A	421203033	1	W005A	for protected lever
	3 positions single-acting on B	421203034	1	W006A	for protected lever
4 positions double-acting with float in the 4 th pos.	421203028	1	W012A	for protected lever	
	421203118			for hydraulic actuation	
3	Protected lever	320359006	1	H001 = H002	
		320359002			only for W012 spool
	Control without lever	320303020	1	H004	
		320303021			only for W012 spool
	Protected vertical safety lever	320303012	1	H015 = H016	
	Protected horizontal safety lever	320303010	1	H017 = H018	
	Hydraulic actuation with side ports	320503001	2	H005	
		320503003	1		only for W012 spool



Ref.	Description	Order code	Q.ty	Code	Note
3	Protected lever	320303016	1	H021=H022	
	Control without lever	320303024	1	H024	
	Direct electric control (12 vdc)	320003004	2	H036	only for type "E" spool
	Direct electric control (24 vdc)	320003005	2	H037	
	Joystick control	320630015	1	H009=H012	
		320630014	1	H010=H011	
4	3 position spring centred spool	320703001	1	F001A	
	Detent in A and B	320803001	1	F002A	
	Detent in A	320803002	1	F003A	
	Detent in B	320803003	1	F004A	
	Detent in 4 th position	320803004	1	F005A	only for W012 spool
	Prearrangement dual command	320703002	1	F013A	
	Pneumatic control ON-OFF	321103002	1	F020A=F021A	BSP ports
		-		F135A=F136A	NPT ports
	Proportional Pneumatic control	321203002	1	F022A=F023A	BSP ports
		-		F126A=F127A	NPT ports
	Electropneumatic control ON-OFF (12 vdc)	321603001	1	F0620	
	Electropneumatic control ON-OFF (24 vdc)	321603002	1	F0630	
	Load limit in A and B	320003020	1	F024A=F025A	
	Load limit in A	320003018	1	F026A=F027A	
	Load limit in B	320003019	1	F028A=F029A	for protected lever
	Electrical load limit (normally closed contacts)	320003010	1	F0360=F0370	for protected lever
	Electrical load limit (normally open contacts)	320003022	1	F0450=F0460	for without lever
	Electrohydraulic ON-OFF (12 vdc)	321403021	1	F1600	for without lever
	Electrohydraulic ON-OFF (24 vdc)	321403022	1	F1610	for hydraulic actuation
	Electrohydraulic Proportional (12 vdc)	322003001	1	F2600	for direct electrical control
	Electrohydraulic Proportional (24 vdc)	322003002	1	F2610	for protected lever
	Electrohydraulic ON-OFF (12 vdc) with reducing valve	321403023	1	F1500=F1520	BSP ports
	Electrohydraulic ON-OFF (24 vdc) with reducing valve	321403024	1	F1510=F1530	BSP ports
	Electrohydraulic Proportional (12 vdc) with reducing valve	322003003	1	F2500=F2520	BSP ports
	Electrohydraulic Proportional (24 vdc) with reducing valve	322003004	1	F2510=F2530	BSP ports
	Electrohydraulic ON-OFF (12 vdc) with reducing valve	321403028	1	F1500=F1520	UNF ports
	Electrohydraulic ON-OFF (24 vdc) with reducing valve	321403029	1	F1510=F1530	UNF ports
	Electrohydraulic Proportional (12 vdc) with reducing valve	322003012	1	F2500=F2520	UNF ports
Electrohydraulic Proportional (24 vdc) with reducing valve	322003013	1	F2510=F2530	UNF ports	
5 Check valve on the work section	320230006	1	-	only for RP and RT section	
6	Antishock valve on port A	4044			Setting: 100 bar
		6891		01 PA	Setting: 200 bar
		9778			Setting: 300 bar
	Anticavitation valve on port A	915083001	1	02 PA	
		23504			Setting: 100 bar
	Combined valve on port A	14779		03 PA	Setting: 200 bar
		38346			Setting: 300 bar
	Prearrangement for auxiliary valve on port A	430430001		05 PP	
7	Antishock valve on port B	4044			Setting: 100 bar
		6891		01 PB	Setting: 200 bar
		9778			Setting: 300 bar
	Anticavitation valve on port B	915083001	1	02 PB	
		23504			Setting: 100 bar
	Combined valve on port A	14779		03 PB	Setting: 200 bar
		38346			Setting: 300 bar
	Prearrangement for auxiliary valve on port B	430430001		05 PB	
8	Plug kit (G 1/2)	430000019		G04	
	Plug kit (3/4" - 16 UNF)	300001006	1	U03	
	Plug kit (M18 x 1.5)	300004002		M01	
	Plug kit (M22 x 1.5)	300004005		M02	
9 Check valve	320230006	1			



Note

- (*) = for different settings please contact our Sales Dpt.
- (**) = electric dump valve coil can be ordered separately as spare part: (see drawing "A")
 Ordering code Coil 12 vdc: **413171235**
 Ordering code Coil 24 vdc: **413172432**

Coil - 12 Vdc = 413171235
 Coil - 24 Vdc = 413172432

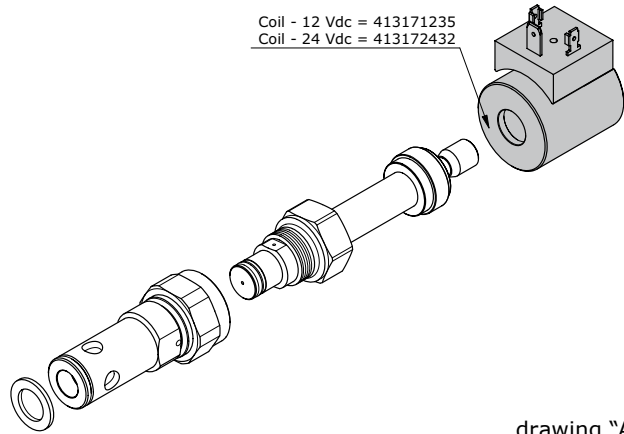

drawing "A"

Gasket kit

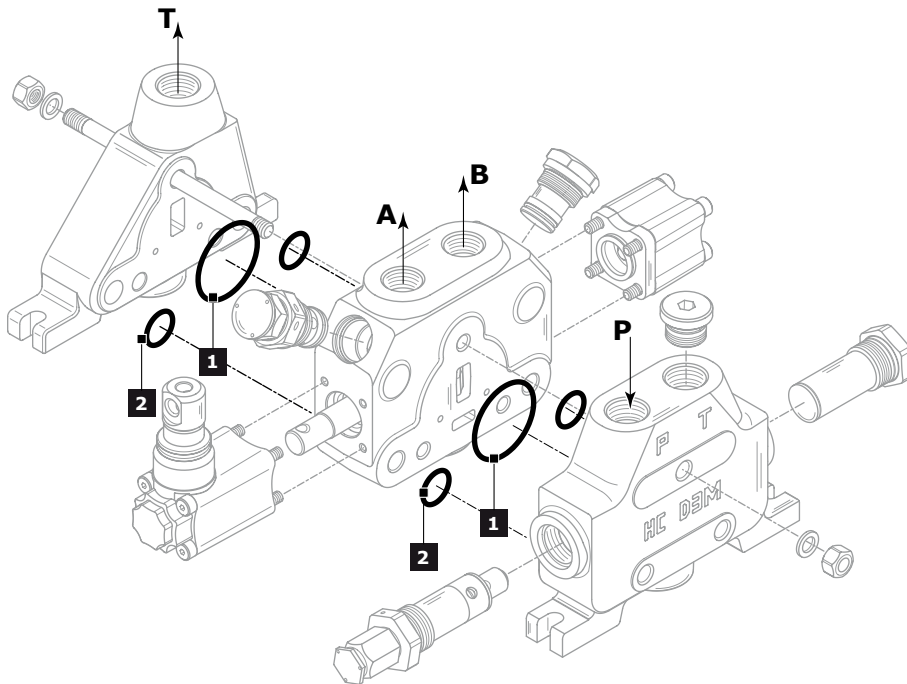

Outlet and work section			
Rif.	Order code	Description	Q.ty
1	412010127	O.R. 70SH 41,00 x 1,78 (2-30)	1
2	412010106	O.R. 70SH 17,17 x 1,78 (2-17)	2

Complete Gasket kit: order code - 350930001



INSTALLATION

Guidelines

- Mount the control valve securely to a flat surface (recommended 3 point fixing); at the time do not use a hammer to positioning by hitting.
- When handling the control valve, be careful not hold the pilot cover or return spring cap of the spool or accessory valves such as main relief valves and anti-shock relief valves.
- Clean piping materials sufficiently before use.
- Make sure to prevent the port openings from being entered with dust or foreign matters.
- Tighten the port connectors surely with the recommended fastening torques.
- Do not direct the jet of a pressure washing unit directly to the valve.

Fittings tightening torque (Nm)

thread type	port P	Port A - B	Port T
BSP (ISO - 228)	G 1/2	G 1/2	G 1/2
with rubber sealing (DIN 3869)	70	70	70
with copper or steel and rubber washer	70	70	70
UN-UNF (ISO - 725)	3/4" - 16 UNF	3/4" - 16 UNF	3/4" - 16 UNF
with O.R.	40	40	40
METRIC (ISO - 262)	M18 x 1,5	M18 x 1,5	M22 x 1,5
with O.R.	80	80	80

General clamping torque

The following table provides the main tightening torques of the distributor HC-D3M:

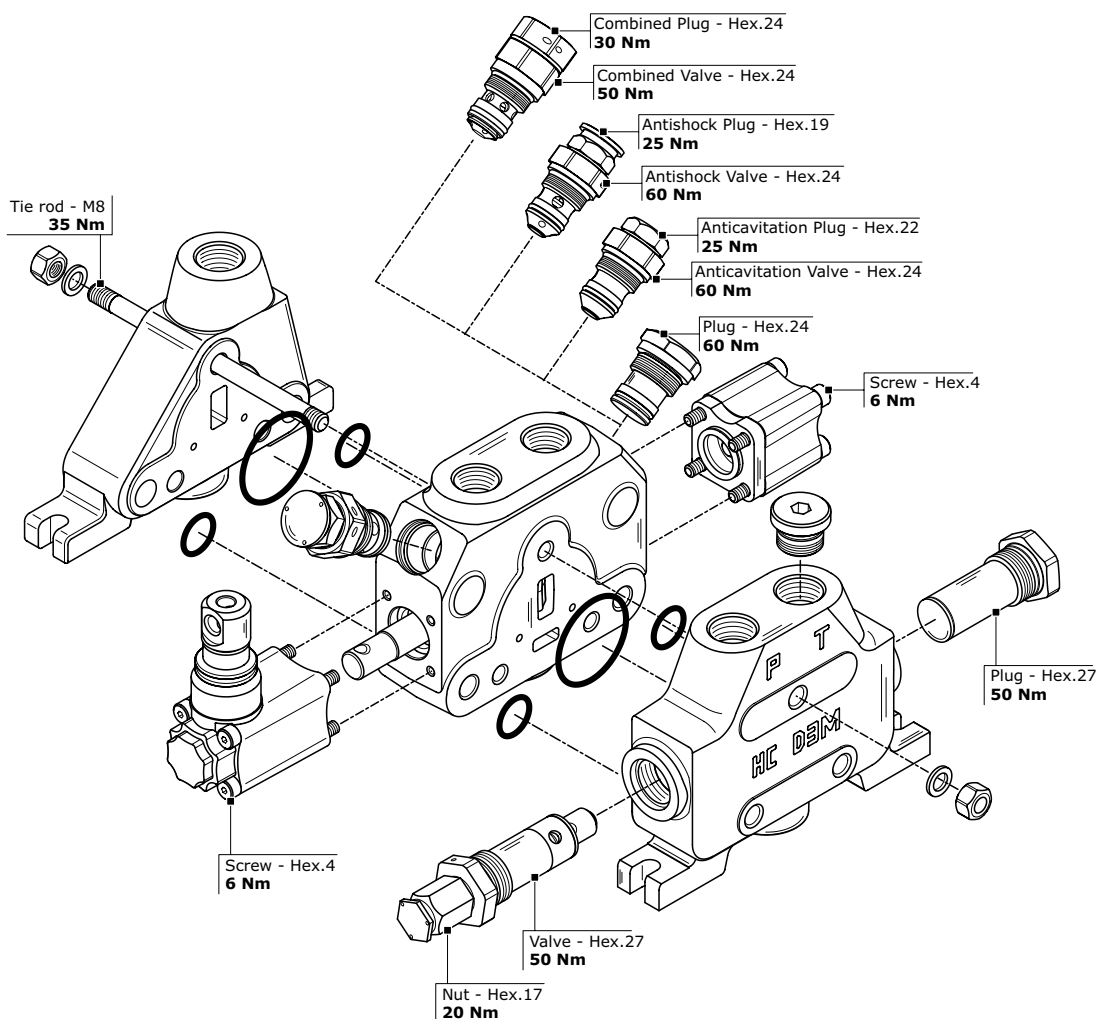



Dimensions - Thread codes

The connection ports size is indicated by an ordering code common for all Hydrocontrol products. Following table shows all available connections.

METRIC THREAD (ISO 9974-1)			
Type	M18x1,5	M22x1,5	M27x2
Code	M01	M02	M03

BSP THREAD (ISO 1179-1)								
Type	1/4"	3/8"	1/2"	3/4"	1"	1 1/4"	1 1/2"	2"
Code	G02	G03	G04	G05	G06	G07	G08	G09

UN / UNF THREAD (ISO 11926-1)						
Type	9/16" 18 UNF SAE6	3/4" 16 UNF SAE8	7/8" 14 UNF SAE10	1 1/16" 12 UNF SAE12	1 5/16" 12 UNF SAE16	1 5/8" 12 UNF SAE20
Code	U02	U03	U04	U05	U06	U07

Dimensions - SAE Flange codes

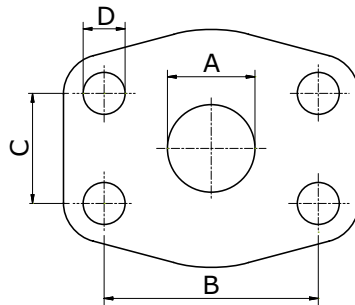

SAE / 3000 FLANGE (ISO 6162-1)												
Type	3/4" (MA)	3/4" (UNC)	1" (MA)	1" (UNC)	1 1/4" (MA)	1 1/4" (UNC)	1 1/2" (MA)	1 1/2" (UNC)	2" (MA)	2" (UNC)	3" (MA)	3" (UNC)
Code	S03	S04	S05	S06	S07	S08	S09	S10	S11	S12	S15	S16
A	19	19	25	25	32	32	38	38	51	51	76	76
B	47,6	47,6	52,4	52,4	58,7	58,7	69,9	69,9	77,8	77,8	106,4	106,4
C	22,3	22,3	26,2	26,2	30,2	30,2	35,7	35,7	42,9	42,9	61,9	61,9
D	M10	3/8-16	M10	3/8-16	M10	7/16-14	M12	1/2-13	M12	1/2-13	M16	5/8-11

SAE / 6000 FLANGE (ISO 6162-2)								
Type	3/4" (MA)	3/4" (UNC)	1" (MA)	1" (UNC)	1 1/4" (MA)	1 1/4" (UNC)	1 1/2" (MA)	1 1/2" (UNC)
Code	S33	S34	S35	S36	S37	S38	S39	S40
A	19	19	25	25	32	32	38	38
B	50,8	50,8	57,2	57,2	66,6	66,6	79,3	79,3
C	23,8	23,8	27,8	27,8	31,8	31,8	36,5	36,5
D	M10	3/8-16	M12	7/16-14	M14	1/2-13	M16	5/8-11



GENERAL CONDITIONS AND PATENTS

Product identification

All Hydrocontrol products have an identifying plate placed in specific position.

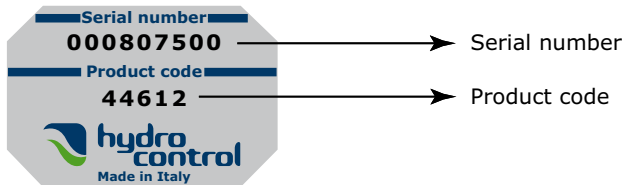

Serial number:

It univocally identifies the physical valve: this provides an easy way to find all sales and production details.

Product code:

It is a number univocally identifying the configuration and pressure settings of a valve.

Introduction

These general conditions apply to all general supplies from Hydrocontrol s.p.a., after receiving orders from the Customer. Should commercial terms such as EXW, DDP, etc be mentioned, of course the Incoterms of the International Chamber of Commerce must be referred to, according to the test existing when the general supply conditions are agreed on.

Management of orders

No Customer's order is binding to Hydrocontrol s.p.a. if Hydrocontrol s.p.a. has not confirmed the order in writing. Hydrocontrol s.p.a. commits to supplying the orders in compliance with the order confirmation that has been issued. Any disagreement with the content of the order confirmation must be communicated in writing to Hydrocontrol s.p.a. within and no later than 5 days from the delivery of the order confirmation. The Customer commits to paying for the goods supplied by Hydrocontrol s.p.a., according to the prices indicated on the order confirmation.

Payment conditions

The Parties agree on the payment terms at the beginning of the supply. The terms will be indicated on the order confirmation. Should the Customer be late with the payments, Hydrocontrol S.p.a. will be entitled to require the payment of interests on arrears based on the exiting Prime Rate increased by 2%. Should there be any payment delay, Hydrocontrol s.p.a. will be entitled not to process the Customer's purchase order, even if it has already been confirmed.

Delivery and shipment

The goods are always supplied Ex Works, even when Hydrocontrol s.p.a. agrees with the Customer that the shipment, or a part of it, will be arranged by Hydrocontrol s.p.a. It is agreed that the Customer will bear the risk of goods deterioration or damaging from the moment the goods are handed by Hydrocontrol s.p.a. to the first carrier.

Product characteristics

Hydrocontrol s.p.a. commits to supplying good quality products, compliant with the technical specifications declared on the technical tables and on the catalogue. Hydrocontrol s.p.a, even without notice, at its own discretion, reserves the right to modify the products as necessary, without these changes altering the main characteristics of the products.

Claims

Any claims about defects on delivered products (just as an example: claims about the packaging, the number, the quantity or the external product characteristics) will have to be notified to Hydrocontrol s.p.a. in writing, within and no later than 7 days from reception of the goods, otherwise the claims will be considered as null and void. Occult defects (the defects of the goods that cannot be spotted with a careful control of the goods received by the Customer), will have to be notified in writing to Hydrocontrol s.p.a. within 7 days from the discovery of the defect, and anyhow no later than 12 months from the delivery of the goods, otherwise the claim will be considered as null and void. Even in case of claim or objection, the Customer will never be entitled to suspend or delay the payments to Hydrocontrol s.p.a. for the products subject to claim or objection nor for any other supply.

**GENERAL CONDITIONS AND PATENTS****Warranty**

Should the products supplied by Hydrocontrol not be compliant or have the required quality and should this defect be due to Hydrocontrol, Hydrocontrol s.p.a. commits, at its choice, to replace or repair the faulty products, as long as the defect or lack of compliance is notified to Hydrocontrol s.p.a. in writing, as specified at point 6, within and no later than 18 months from product delivery. On the products that have been fixed or replaced in accordance with what specified above, the above-mentioned warranty applies. The 12 month duration starts from the date of repair or replacement. In case of defects, lack of quality or in case of lack of compliance for the supplied products, with the exception of fraud or serious offence, Hydrocontrol s.p.a. only commits to repairing or replacing the faulty products, according to what specified above. This warranty replaces any other Supplier's warranty or liability established by the law. This warranty excludes any other liability contractual or extra-contractual by Hydrocontrol s.p.a. on the products supplied by Hydrocontrol (as a mere example: damage refund, loss of profit, product recall campaign, etc). Hydrocontrol s.p.a. has signed a product civil liability police, with a suitable maximum coverage.

Ownership retention

The products supplied by Hydrocontrol s.p.a. will be owned by the latter until Hydrocontrol receives the complete payment for the supplied goods.

Obligation confidentiality

Hydrocontrol s.p.a. commits to not disclosing the technical and commercial information it receives from the Customer, unless this information has already been publicly disclosed.

Patents

The Customer is not allowed to use the provided Products, or a part of them, their descriptions or drawings protected or not protected by Patent or registered trademark in order to design or make similar products, unless Hydrocontrol s.p.a. previously issues its written authorization. Should Hydrocontrol s.p.a. give its written authorization, all patents, trademarks, registered designs, copyrights and intellectual property rights related or connected to the Products provided by Hydrocontrol s.p.a. will stay Hydrocontrol's property. The Customer commits to respecting the highest confidentiality.

Applicable law and court of jurisdiction

Hydrocontrol s.p.a.'s supplies are regulated by these General Supply Conditions and, for anything not defined here, by the Italian law. Any controversy related, generated or connected to the supply of Products by Hydrocontrol s.p.a., where Hydrocontrol s.p.a. is involved, will be exclusively dealt with by the Court of Bologna.

Walvoil nel mondo - Walvoil worldwide
Sede principale, Filiali e Uffici di rappresentanza
Headquarters, Subsidiaries and Representative Offices

Walvoil S.p.A. - Headquarters

Via Adige, 13/D . 42124 Reggio Emilia . Italy
Phone +39 0522 932411 . info@walvoil.com - www.walvoil.com

Business Unit Hydrocontrol

Via San Giovanni, 481 . 40060 Osteria Grande
Castel S. Pietro Terme . Bologna . Italy
Phone +39 051 6959411

Galtech Site

Via Portella della Ginestra, 10 . 42025 Cavriago
Zona Industriale Corte Tegge . Reggio Emilia . Italy
Phone +39 0522 932411

AUSTRALASIA

Walvoil Fluid Power Australasia Pty Ltd

13 Vanessa Way . Delahey VIC 3037 . Melbourne . Australia
TEL. 0061 458 918 750 . australasia@walvoil.com

BRASILE . BRAZIL

Interpump Hydraulics Brasil Ltda - Walvoil Division

Gilberto de Zorzi, 525 . Forqueta Caxias do Sul (RS)
TEL. 0055 54 3223 2373 . infobrasil@walvoil.com

CANADA

Galtech Canada Inc.

3100, Jacob Jordan . Terrebonne . Qc J6X 4J6 . Canada
Phone +1 450 477 1076 Ext:225 . info@galtechcanada.com

CINA . CHINA

Walvoil Fluid Power (Shanghai) Company Limited

24, Lane 129, Dieqiao Road . Pu Dong . Kanqiao Industrial Zone Shanghai (201319)
TEL. 0086 21 60979800 . info@walvoil.com.cn

Guangzhou Bushi Hydraulic Technology Ltd

Shangwei Shaheshe, Yuehu Village . Xiancun, Xintang Town . Zengcheng City
511335 Guangzhou . Guangdong Province China
Phone +86 021 52380695 . fareast@hydrocontrol-inc.com

COREA DEL SUD . SOUTH KOREA

Walvoil Fluid Power Korea Ltd.

80-15, Oseongsandan 1Ro, Oseong-Myun, Pyungtaek, Kyungki . Korea 451-872
TEL. +82 31 682 6030 . info@walvoil.co.kr

FRANCIA . FRANCE

Walvoil Fluid Power France

362 rue de Bretagne . 44540 Vritz
TEL. 0033 2 41 94 41 06 . france@walvoil.com

INDIA

HC Hydraulic Technology(P) LTD

A5(B) Ngef Ancillary Indl. Estate . Whitefield Road
Mahadevpura (Po) . Bangalore 560048 . India
Phone +91 080 40454707 . info@hydrocontrol-india.com

Walvoil Fluid Power (India) PVT. LTD.

No 23, Doddanakundi Industrial Area Mahadevpura Post Behind Graphite India
Bangalore 560 048
TEL. 0091 80 41842900 . info@walvoil.co.in

U.S.A.

Hydrocontrol Inc.

1109, Technology Drive . Red Wing . MN 55066 . U.S.A.
Phone +1 651 212 6400 . usa@hydrocontrol-inc.com

Walvoil Fluid Power Corporation

4111 North Garnett Tulsa, OK 74116, USA
TEL. 001 918 858 7100 . info@walvoilfluidpower.com

1st edition D3M.05

www.hydrocontrol-inc.com



D1WHEB02E

